

Manufacturing Processes

UNIT-I (Metal Casting)

Introduction to Manufacturing:

The word manufacture is derived from two Latin words, manus (hand) and factus (make); the combination means “made by hand”.

Technologically, manufacturing is the application of physical and chemical processes to alter the geometry, properties, and/or appearance of a given starting material to make parts or products; manufacturing also includes assembly of multiple parts to make products. The processes to accomplish manufacturing involve a combination of machinery, tools, power, and labor, as depicted in Figure.

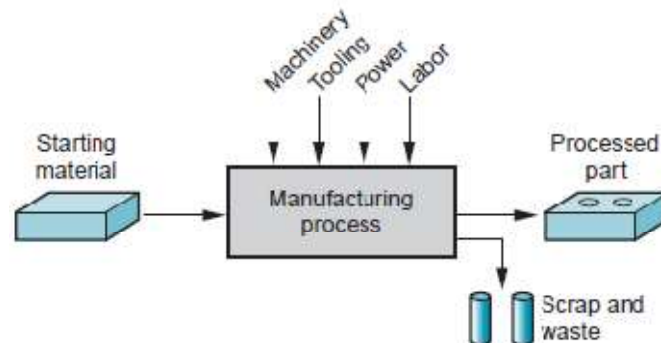

Economically, manufacturing is the transformation of materials into items of greater value by means of one or more processing and/or assembly operations. The key point is that manufacturing adds value to the material by changing its shape or properties, or by combining it with other materials that have been similarly altered. The material has been made more valuable through the manufacturing operations performed on it.

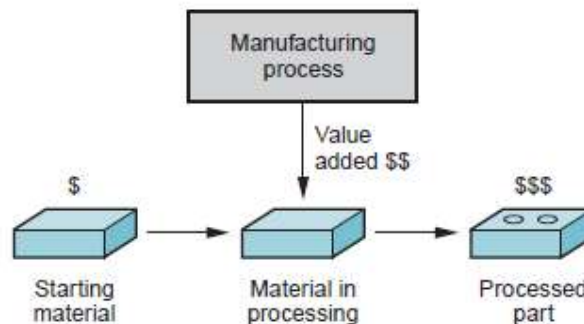

Classification of Manufacturing Processes:

The manufacturing processes can be classified as:

- Casting, foundry, or moulding processes
- Forming or metalworking processes
- Machining (material removal) processes
- Joining and assembly
- Surface treatments (finishing)
- Rapid prototyping
- Heat treating
- Other (Inspection, testing, transportation and even packaging).

In casting, the metal is heated sufficiently to make it into liquid and then poured into moulds of desired shapes. Various machining operations are turning, drilling and milling. Joining processes include welding, soldering, brazing and adhesive bonding.

The process of heat treating is carried out to enhance various properties and include annealing and strengthening processes for metals and glasses. Surface processing includes cleaning, coating and thin film deposition, electroplating, anodising etc.

The following hierarchy will give you brief idea about the classification of manufacturing processes.

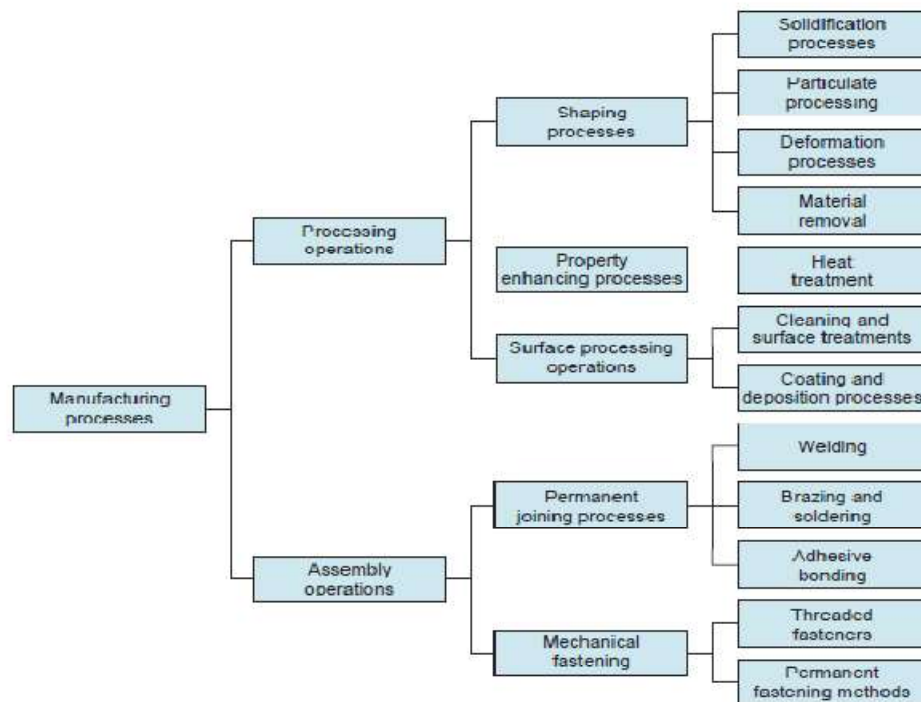

METAL CASTING

“Metal Casting is one of the oldest materials shaping methods known. Casting means pouring molten metal into a mold with a cavity of the shape to be made, and allowing it to solidify. When solidified, the desired metal object is taken out from the mold either by breaking the mold or taking the mold apart. The solidified object is called the casting.”

(Or)

“Casting is a process in which molten metal flows by gravity or other force into a mold where it solidifies in the shape of the mold cavity.”

Advantages:

- Casting can be used to create complex part geometries, including both external and internal shapes.
- Some casting processes are capable of producing parts to net shape. No further manufacturing operations are required to achieve the required geometry and dimensions of the parts.
- Other casting processes are near net shape, for which some additional shape processing is required (usually machining) in order to achieve accurate dimensions and details.
- Casting can be used to produce very large parts. Castings weighing more than 100 tons have been made.
- The casting process can be performed on any metal that can be heated to the liquid state.
- Some casting methods are quite suited to mass production.

Draw backs:

- Limitations on mechanical properties, porosity, poor dimensional accuracy and surface finish for some casting processes.
- Safety hazards to humans when processing hot molten metals
- Environmental problems.

Steps involved in casting:

The following are the basic steps involved in casting process:

- Pattern Making
- Mold making
- Melting
- Pouring
- Solidification
- Fettleing, Cleaning & Finishing
- Inspection

The following diagram shows the flow of steps in casting:

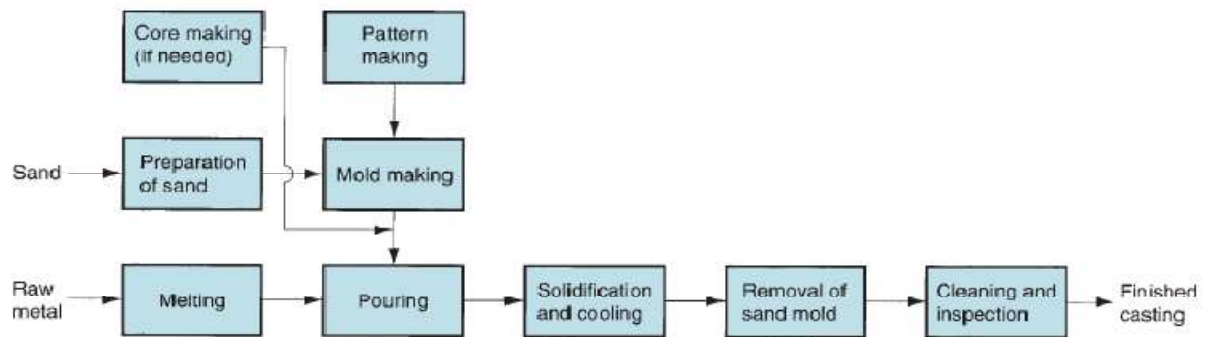

Pattern Making

The process of making a wooden or metallic pattern is known as pattern making. Pattern acts as a principle tool during the casting process and can be defined as a model of desired casting or replica of the cast to be produced.

Pattern Materials: Some of the common materials used for pattern making are wood, metal, plaster, wax and plastic.

- **Wood:** Wood is the most common material used for pattern making as it satisfies most of the essential requirements which are considered for a good pattern. It is light in weight and easily available at low cost, may be easily shaped into different forms as obtained good surface finish easily. The most common woods used for pattern are Deodar, Teak and Mahogany.
- **Metal:** It is used for pattern when a large number of casting with a closer dimensional accuracy is desired. The pattern of metal has a much longer life than wooden pattern as it does not change its shape when subjected to moist conditions. A metal pattern is itself cast from a wooden pattern called “Master Pattern”. Cast-iron, aluminium and its alloys, brass and white metal are commonly used as a pattern metals.
- **Plaster:** Plaster of Paris (gypsum cement) is also used for making patterns and core boxes. It can be easily worked and casted into desired shape. It has a high compressive strength (up to 300 kg/ cm²). Its specific use is in making small patterns and core-boxes involving intricate shapes and closer dimensional control.
- **Wax:** Patterns which are generally used in investment casting process are made by wax. The wax patterns are made by pouring the heated wax into a split die or metal mould. The die is kept cool by circulating the water around it. After complete cooling, the die parts are separated and wax in shape of pattern is taken out.
- **Plastic:** At present, plastics are finding their place as a pattern material due to their specific characteristics such as high strength and resistance to wear, lightness in weight, fine surface finish and low solid shrinkage etc.

Types of Pattern: The type of patterns selected for a particular casting depends upon many factors such as type of molding process, number and size of casting and anticipated difficulty of moulding on account of design or typical shape of casting. The most common types of pattern are listed and described below:

- Solid or Single Piece Pattern
- Split Pattern
- Gated Pattern
- Loose Piece Pattern
- Sweep Pattern
- Match Plate Pattern
- Cope & Drag Pattern
- Follow board Pattern
- Skeleton Pattern

Solid or Single Piece Pattern:

- This type of pattern is the simplest of all the patterns. It is made without joints, partings or loose pieces. For moulding with two patterns, one or two moulding boxes may be used. Moulding operation with this pattern takes more times as the moulder has to cut his own runners, risers and feeding gates. These types of patterns are usually used for simple and large sizes of casting.

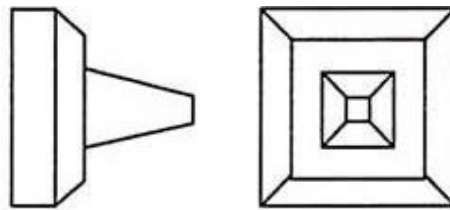

Split Pattern

- Whenever the design of casting offers difficulty in making of mould and withdrawal of pattern with a single piece pattern, split or two-piece pattern is most suitable. This type of pattern eliminates this difficulty and can be used to form the mould of intricate design or unusual shape of casting. Split patterns are made in two parts so that one is placed in cope and other in drag with the dowel pins holding the two together. The surface formed at the line of separation of the two parts, usually at the centre line of the pattern, is called parting line.

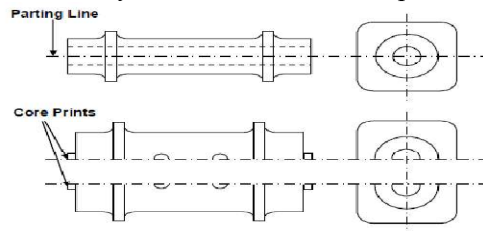

Gated Pattern

- In mass production, a number of castings are prepared in a single multi cavity mould by joining a group of patterns. In such type of multi cavity mould, gates or runners for the molten metal are formed by connecting parts between the individual patterns. These are made of wood or metal and specially used for mass productions of small castings.

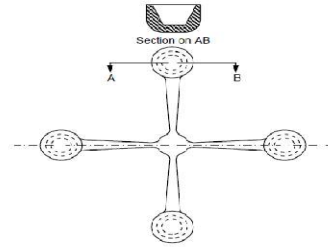

Loose Piece Pattern

- As per requirement, some solid or single piece types of patterns are made as assemblies of loose component pieces. Loose pieces are arranged in such a way that it can be removed from the mould easily. Usually, this type of pattern requires much maintenance and is slower to mould.

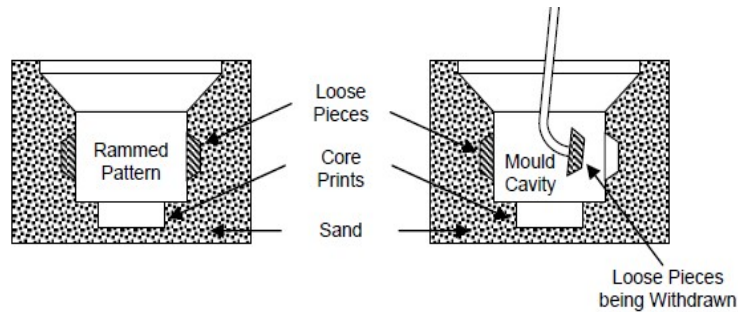

Sweep Pattern

- Large sizes of symmetrical moulds are generally prepared by means of sweep patterns. It consists of a base, a wooden sweep board and a vertical spindle. The outer end of sweep board carries a shape corresponding to the shape of desired casting. Usually, sweep patterns are employed for moulding part carrying circular sections. The sweep board is attached with the vertical spindle. After holding the spindle in vertical position, the moulding sand is rammed in place. As the sweep board is rotated about the spindle it will form a desired cavity in the moulding sand.

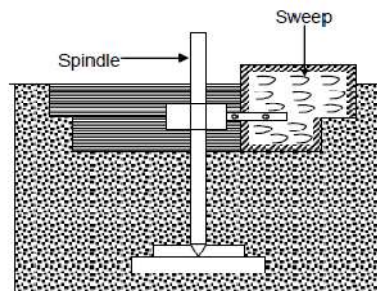

Match Plate Pattern

- These type of patterns are widely used for producing small sizes of castings in mass scale and are made of metal. Match plate patterns are made in two pieces like split patterns. It consists of a wooden or metallic plate, called match plate. Both the parts of split pattern are mounted on both sides of this match plate. Groups of patterns on both sides of match plates are used to prepare the moulds at a time separately, i.e. for group of patterns on one side is prepared in drag while the other side group of patterns in cope.

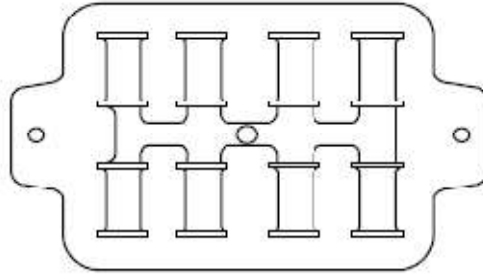

Cope and drag pattern

- When very large castings are to be made, the complete pattern becomes too heavy to be handled by a single operator. Such pattern is made in two parts which are separately moulded in different moulding boxes. After completion of the moulds, the two boxes are assembled to form the complete cavity. It is similar to two-piece pattern.

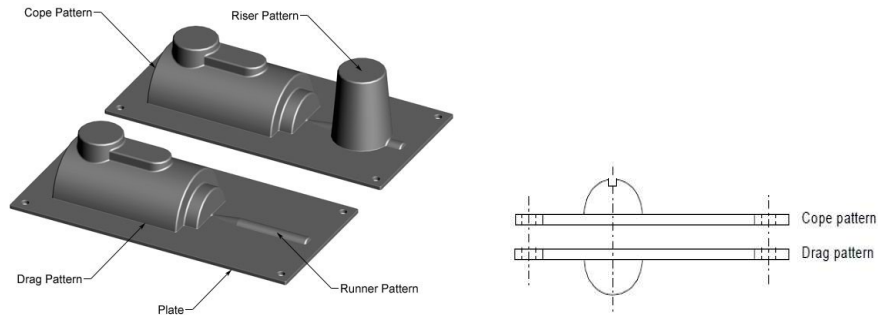

Follow board pattern

- This pattern is adopted for those castings where there are some portions, which are structurally weak and if not supported properly are likely to break under the force of ramming. Hence the bottom board is modified as a follow board to closely fit the contour of the weak pattern and thus support it during the ramming of the drag.

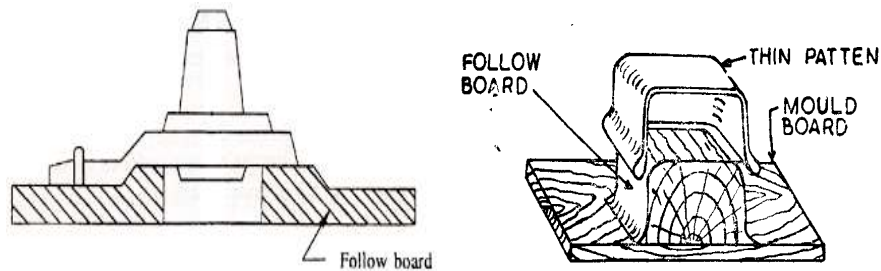

Skeleton pattern:

- For large castings having simple geometrical shapes, skeleton patterns are used. Just like sweep patterns, these are simple wooden frames that outline the shape of the part to be cast and are also used as guides by the molder in the hand shaping of the mould. This type of pattern is also used in pit or floor molding process.

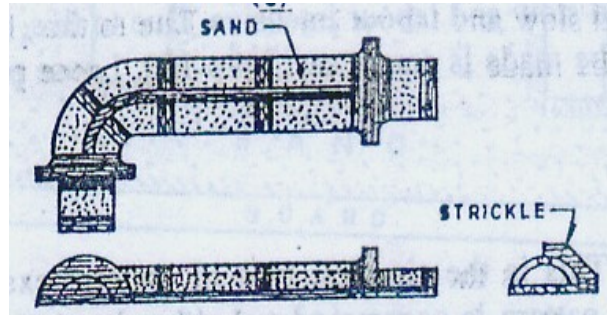

Pattern Allowances:

Usually, the pattern is always made larger than the desired size of the casting on account of allowance which should be allowed for machining, shrinkage, distortion and rapping etc. For a pattern, the following allowances are provided :

- **Machining Allowance:** The extra amount of metal provided on the surfaces of casting to be machined is called as a machining allowance. The amount of this allowance depends upon the method of casting used, metal of casting, method of machining. Size and shape of casting etc. Ferrous types of metals require more allowance comparative to non-ferrous metals.
- **Shrinkage Allowance:** Metals used for casting usually shrink and contract due to solidification and cooling. It is compensated by providing adequate amount of allowance in the pattern which is called as shrinkage allowance.

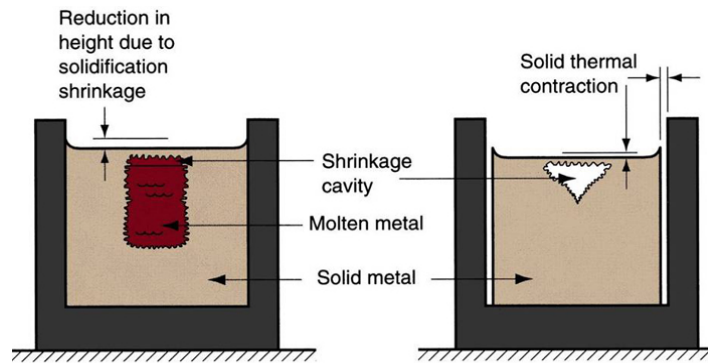

- **Distortion Allowance:** Casting of irregular shape and design tend to distort during cooling period. Distortion of casting will take place due to uneven metal thickness, shrinkage and rate of cooling. To eliminate this defect, distortion in opposite direction is provided in the pattern so that this effect of distortion may be neutralized.

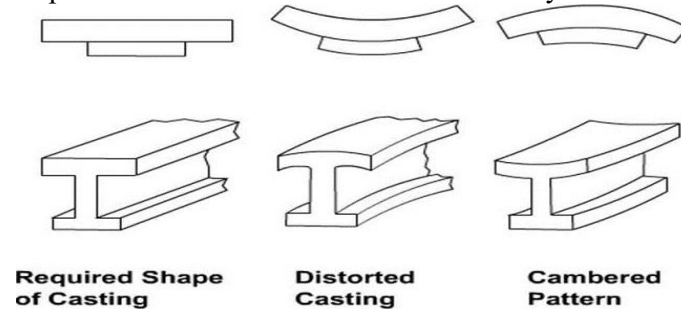

- **Rapping Allowance:** When a pattern is withdrawn from a mould, rapping is used in the pattern. As a result of this rapping, the cavity in the mould is slightly increased.

Therefore, a negative allowance is to be provided in the pattern to compensate the same. It is also called as shake allowance

- **Draft Allowance:** To facilitate easy and early withdrawal of pattern from the mould without injuring the vertical surfaces and edges of mould, patterns are given a slight taper on all vertical surfaces. This slight taper inward on the vertical surfaces of a pattern is known as the draft or draft allowance. Draft allowance may be expressed either in degrees or in terms of millimeter per metre on a side. Its amount varies from 10 mm to 25 mm per metre on external surfaces and from 40 mm to 70 mm per metre on internal surfaces.

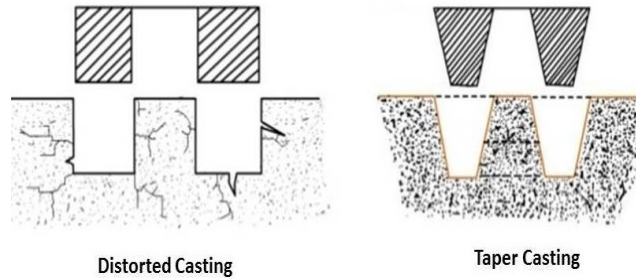

Example Problem on Pattern size calculation:

1. The cast shown in figure is to be made in cast iron using a wooden pattern. Assuming only shrinkage allowance, calculate dimensions of the pattern. Cast iron shrinkage = 10mm/m

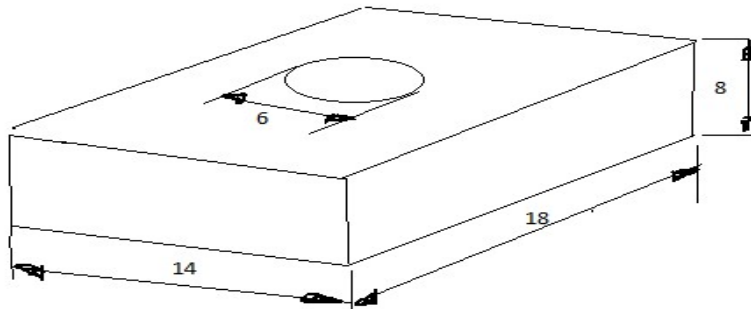

2. A job to be made by steel by casting process. the mold for the job is made from a wooden pattern. Determine pattern size if
 - (i) Machining allowance is 2mm on each side.
 - (ii) Shrinkage allowance 2 %
 - (iii) Taper allowance is 1°

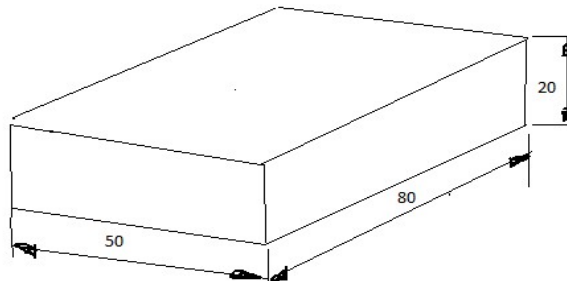

3. A job shown in figure is to be made from steel by casting process. the mold for this job is made from wooden pattern. determine the dimensions of the wooden pattern assuming machining allowance 3 mm on each side, shaking allowance of 1 mm on length and width and shrinkage allowance of 3%.

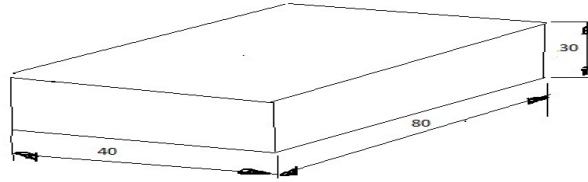

4. Design a wooden master pattern to produce a steel casting as shown in figure. Consider only shrinkage allowance. Steel shrinkage allowance is 21mm/m.

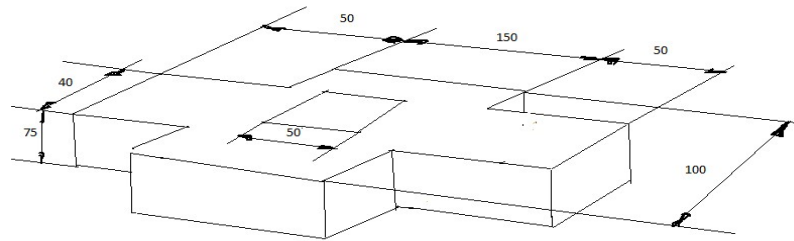

Mold Making

Metal casting processes divide into two categories, based on mold type:

- (1) Expendable mold (2) Permanent mold.

In expendable mold casting operations, the mold is sacrificed in order to remove the cast part.

Ex: Sand Casting

The mould is a cavity or impression in the moulding sand which is produced by means of pattern. The process of producing this cavity is known as “moulding”.

Composition of Molding Sand: The principal constituents of molding sand are silica sand, binder, additives and water. These are described below:

- **Silica Sand:** Silica sand is the main constituent of molding sand. It is a product of the breaking up of quarry stone or decomposition of granite. Silica sand imparts permeability, chemical resistivity and refractoriness to the molding sand. Silica sand is specified according to the average shape and size of its grains.
- **Binder (Clay):** The main function of binder is to impart the sufficient strength and cohesiveness of the molding sand, so that it may retain its shape after ramming. The common binders may be divided as

- (i) Organic binders (ii) Inorganic binders.

The organic binders such as molasses, dextrin, linseed oil and resins are usually used in core making while in the inorganic group the common binders are Portland cement, clay and sodium silicate. Amongst all, the clay binders are widely used.

- **Water:** When water is added to clay it furnishes the bounding action of clay. It penetrates the mass of clay and forms a microfilm. The bonding quality of clay totally depends on the maximum thickness of microfilm it can hold. In general, water quantity varies from 2 to 8 percent.
- **Additives:** Materials which are added to the molding sand to improve its existing properties or to include certain new properties are known as additives. As per demand coal dust, wood flour, molasses, corn flour and pitch may be used as an additive.

Types of Molding Sand: Molding sands are classified according to their use. These are classified and described below:

- **Green Sand:** It is a mixture of silica sand with 18 to 30 percent clay, having quantity of water 6 to 8 percent. Green sand in its natural state contains enough moisture to give it sufficient bonding property. It is soft, light, porous and retains the shape easily when squeezed in the hand. Moulds prepared by this sand are known as green sand moulds which are used for small and medium castings only.
- **Dry Sand:** When moisture from green sand mould is removed, it is known as dry sand mould and is used for large size of casting. By drying the mould in molding box it becomes stronger and compact.
- **Facing Sand:** It is used directly next to the surface of pattern. When the mould is poured with the molten metal it comes directly in contact with the molten metal. As it is subjected to most severe conditions, it must possess high strength and refractoriness. It is made of silica sand and clay in fine powder form.
- **Loam Sand:** It is a mixture of clay (about 50%), sand and water (about 18-20%) to obtain a thin plastic paste which is used to plaster on moulds with soft bricks and hardens on drying. This is particularly employed for loam molding usually for rough and large castings.
- **Backing Sand:** It is the sand obtained from mould and is used again and again. Due to its black colour which is due to burning and addition of coal dust, it is also known as black sand.
- **Parting Sand:** It is fine sharp dry sand used to keep the green sand from sticking to the pattern and also to keep the molding boxes (drag and cope) separated.
- **Core Sand:** This is silica sand mixed with core oil which is composed of linseed oil, light mineral oil, resin and other binding materials. For the sake of economy, pitch or flours and water may also be used in case of large cores.

Properties of Molding Sand: A good molding sand must possess the under mentioned properties of porosity, plasticity, adhesiveness, cohesiveness and refractoriness etc.

- **Porosity or Permeability:** The passage of gaseous materials, water and steam vapour through the molding sand is related to porosity. Molten metal always contains a certain amount of dissolved gases, which are evolved during the solidification of metal. A very large volume of gas and steam is also generated when the molten metal is poured into the mould due to the heating of moistures, coal dust and similar other materials present in the sand. If these gases are not allowed to escape completely through the mould, they will form pores and gas holes in the casting. So, for a good sand it must be sufficiently porous to allow the gases or moisture present or generated into the atmosphere freely. This property of sand is called porosity.
- **Plasticity or Flowability:** It refers to the condition of acquiring predetermined shape under pressure and to retain it when the pressure is removed. This property of molding sand increases as clay and water content increase.
- **Adhesiveness:** The sand particles must be capable of sticking to the other bodies particularly to the molding box of flask and it is due to only the property of adhesiveness that molding sand mass is held in the molding box properly. Due to this property, molding sand can be manipulated as desired without any chance of its falling out.
- **Cohesiveness:** The ability of sand particles to stick together is denoted as cohesiveness or the strength of molding sand. Due to this property, mould retains its shape even after the molten metal is poured in the mould. In green state this property is termed as “green strength” or “green bond” while for dry state as a “dry strength” or “dry bond”. Cohesiveness property is largely effected by the clay and moisture content, and size of grains.
- **Refractoriness:** It is ability of the silica sand to withstand high temperature without fusing or breaking down as due to poor refractoriness sand may burn at high temperature. This property of sand is measured by the sinter point rather than melting point of sand.

Methods of Molding Processes: The different molding processes may be classified as follows:

According to the method used

- (a) Floor Molding

- (b) Bench Molding
- (c) Pit Molding
- (d) Machine Molding

- **Floor Molding:** This method of molding is commonly used for preparing the mould of heavy and large size of jobs which cannot be conveniently molded through bench molding method. In floor molding, the floor itself acts as a drag. It is preferred for such rough type of castings where the upper surface finish has no importance.
- **Bench Molding :** Bench molding is done on a work bench of a height convenient to the molder. It is best suited to prepare the mould of small and light items which are to be casted by non-ferrous metals.
- **Pit Molding:** Large size of jobs which cannot be accommodated in molding boxes are frequently molded in pits. Here, the pit acts as a drag. Generally, one box, i.e. cope is sufficient to complete the mould. Runner and riser, gates and pouring basin are cut in it.
- **Machine Molding:** Machine molding method is preferred for mass production of identical casting as most of the molding operations such as ramming of sand, rolling over the mould, and gate cutting etc. are performed by the molding machine. Therefore, this method of molding is more efficient and economical in comparison to hand molding.

Types of machine molding operations:

1. Jolting Operation
2. Squeezing Operation
3. Jolting and Squeezing Operations
4. Sand Slinging Operation

➤ **Jolting Operation:**

- ✓ A sand-filled mould is raised to a certain amount of height so that it possesses potential energy. When it is allowed to fall freely on to the ground, the Potential energy is converted into Impact energy and Impact loading which is acting on to the ground.
- ✓ Whereas the equal and opposite reaction impact load produced by the ground will be acting on to the mould for ramming and compressing of the mould called as Jolting Operation.
- ✓ Because the force applied by the ground may not be transmitted up to the top of the mould, hence the bottom of the mould is attaining higher strength and hardness. But the top of the mould is possessing lower strength and hardness.

JOLTING MACHINE

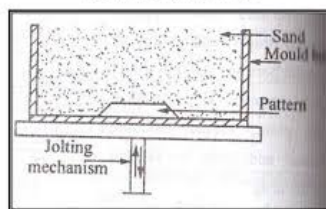

➤ **Squeezing Operation:**

- ✓ A plate is placed on the top of the sand mould and applies the load by using hydraulic or Mechanical press. So, that ramming or compressing of molding sand will be taking place.
- ✓ With the Squeezing operation, higher strength and Hardness of the mould is obtained on top and lower strength and hardness is obtained at the bottom.
- ✓ By combining Jolting and Squeezing operation, it is possible to attain higher strength and hardness throughout the mould. But, Always Jolting will be done first and then Squeezing.

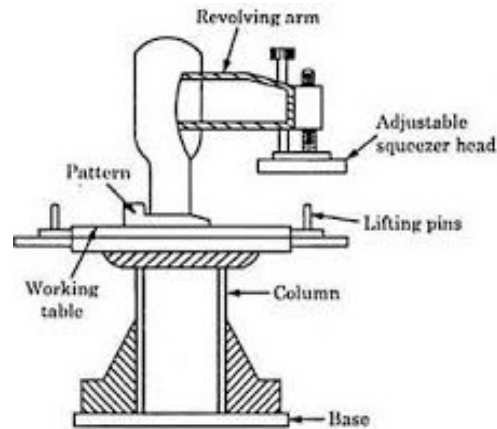

➤ **Jolt & Squeeze operations:**

- ✓ The Jolting and Squeezing methods will give the uniform strength and hardness if the height of the mould is **less than 200 mm**.
- ✓ If the height of the mould is **greater than 200 mm**, top and bottom will be getting higher strength but **middle** of the mould is at **lower strength**.

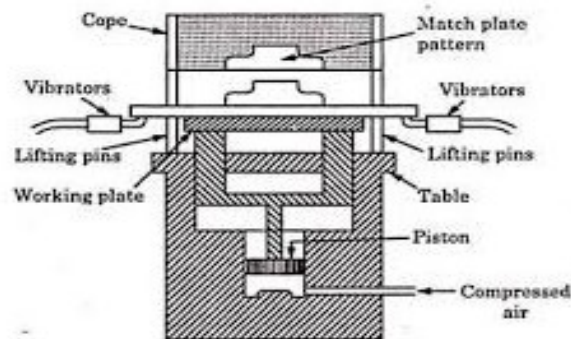

➤ **Sand Slinging Operation:**

- ✓ To get the uniform strength throughout the mould with whatever may be the height of the mould, the best process is Sand Slinging Operation.
- ✓ In Sand slinging operation, small quantities of molding sand will be thrown into the mould with certain amount of force so that localized ramming action will be taking place and it gives the uniform strength and hardness of the mould with whatever may be the height of the mould.
- ✓ The Sand Slinging equipment is costly and also when the molten sand is thrown on to the projection, it may damage the projection present on the pattern.
- ✓ Hence this method cannot be used for producing the moulds with a pattern having projections and Extinctions.

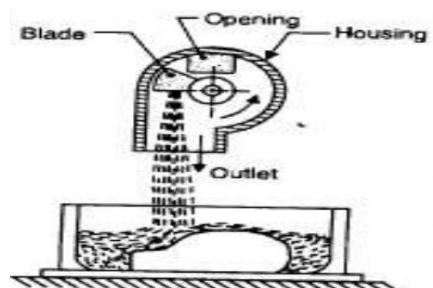

Melting Furnaces

I. Cupola Furnace:

- ✓ Cupola furnace is employed for melting scrap metal or pig iron for production of various cast irons.
- ✓ **Construction:** A typical cupola melting furnace consists of a water-cooled vertical cylinder which is lined with refractory material. Gray Cast iron, nodular cast iron, some malleable iron castings and some copper base alloys can be produced by Cupola Furnace. The schematic representation of various zones and construction details of cupola is as shown in figure.

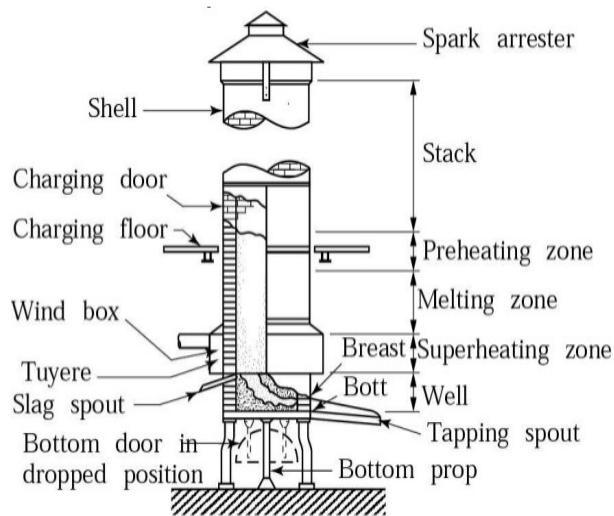

Fig. Schematic representation of Cupola furnace

- ✓ The construction of a conventional cupola consists of a vertical steel shell which is lined with a refractory brick. The charge is introduced into the furnace body by means of an opening approximately half way up the vertical stack Zone.
- ✓ The charge consists of alternate layers of the metal to be melted, coke fuel and limestone flux. The fuel is burnt in air which is introduced through tuyeres positioned above the hearth.
- ✓ The hot gases generated in the lower part of the stack ascend and preheat the descending charge.

➤ Various Zones and reactions of Cupola Furnace:

- ✓ **Well:** The space between the bottom of the tuyeres and the sand bed inside the cylindrical shell of the cupola is called as well of the cupola. As the melting occurs, the molten metal is get collected in this portion before tapping out.

- ✓ **Combustion zone:** The combustion zone of Cupola is also called as oxidizing zone.

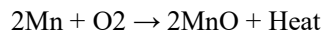
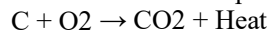

- ✓ **Reducing zone:** Reducing zone of Cupola is also known as the protective zone which is located between the upper level of the combustion zone and the upper level of the coke bed. In this zone, CO_2 is changed to CO through an endothermic reaction, as a result of which the temperature falls from combustion zone temperature to about $1200^\circ C$ at the top of this zone.

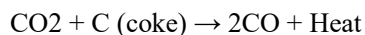

- ✓ **Melting zone:** The lower layer of metal charge above the lower layer of coke bed is termed as melting zone of Cupola. The metal charge starts melting in this zone and trickles down through coke bed and gets collected in the well. Sufficient carbon content picked by the molten metal in this zone is represented by the chemical reaction given as under.

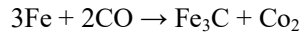

- ✓ **Preheating zone:** Preheating zone starts from the upper end of the melting zone and continues up to the bottom level of the charging door. This zone contains a number of alternate layers of coke bed, flux and metal charge. The main objective of this zone is to preheat the charges from room temperature to about 1090°C before entering the metal charge to the melting zone.
- ✓ **Stack:** The empty portion of cupola above the preheating zone is called as stack. It provides the passage to hot gases to go to atmosphere from the cupola furnace.
- **Charging of Cupola Furnace:**
 - ✓ Before the blower is started, the furnace is uniformly pre-heated and the metal and coke charges, lying in alternate layers, are sufficiently heated up.
 - ✓ The cover plates are positioned suitably and the blower is started. The height of coke charge in the cupola in each layer varies generally from 10 to 15 cms.
 - ✓ The requirement of flux to the metal charge depends upon the quality of the charged metal and scarp, the composition of the coke and the amount of ash content present in the coke.
- **Advantages:**
 - ✓ It is simple and economical to operate.
 - ✓ Cupolas can refine the metal charge, removing impurities out of the slag.
 - ✓ From a life-cycle perspective, cupolas are more efficient and less harmful to the environment than electric furnaces.
 - ✓ The continuous rather than batch process suits the demands of a repetition foundry.
- **Limitations**
 - ✓ Since molten iron and coke are in contact with each other, certain elements like Si, Mn are lost and others like sulphur are picked up. This changes the final analysis of molten metal.
 - ✓ Close temperature control is difficult to maintain.

II. Crucible furnace:

- ✓ It is used for the melting of non ferrous metals. Its capacity may range from 30 to 150 kg.
- ✓ The types of crucible furnace are:
 - 1) Pit furnace
 - 2) Coke fired stationery furnace
 - 3) Oil fired tilting furnace
 - 4) Pot furnace

1) Pit Furnace:

- ✓ The crucible is placed in a pit below the floor level, it is fired with coke.
- ✓ The charge to be melted is placed in crucible. coke is packed around the crucible. Natural draft is provided by a tall chimney. Many crucibles can be placed in a single pit.
- ✓ After the metal is melted, the covers are removed, the crucibles are lift out with the help of tongs and taken to pouring placed.
- ✓ This furnace is used for melting non ferrous metals.

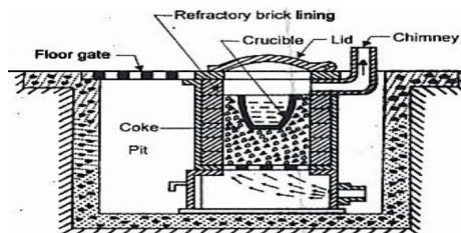

2) Coke Fired Stationary Furnace:

- ✓ This furnace is used for melting non ferrous metals in small quantity.
- ✓ This furnace is placed above the floor level. The crucible is placed in the heating chamber. The heating chamber is lined with refractories.
- ✓ Coke is used as fuel. Forced draft is used.
- ✓ A blower is used for supply of air.

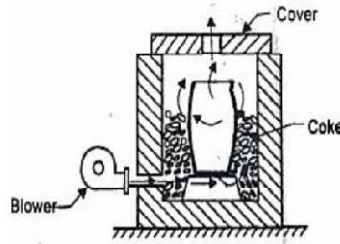

3) Oil Fired Tilting Furnace:

- ✓ This furnace is used for melting non ferrous metals in small quantity and is fired by oil.
- ✓ This furnace is mounted on two pedestals above the floor level. For pouring the molten metal, the furnace is rotated by the geared hand wheel.
- ✓ Oil and air are admitted with pressure through a nozzle. The crucible is placed in the heating chamber and is heated by the flame.
- ✓ The furnace can be stopped whenever needed → & temperature can be controlled easily. They give lesser pollution.

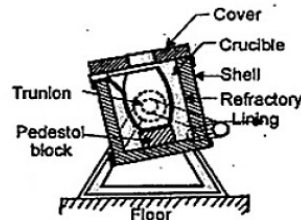

Electric - Arc Furnace:

- ✓ Charge is melted by heat generated from an electric arc.
- ✓ High power consumption, but electric-arc furnaces can be designed for high melting capacity.
- ✓ Used primarily for melting steel.

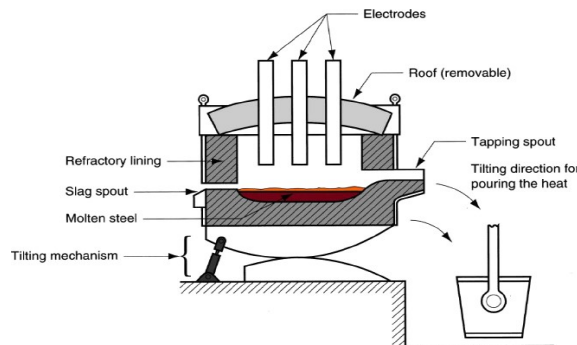

Manufacturing Processes

UNIT-II

Gating System: All the channels or passages through which the molten metal is delivered to mould cavity is termed as gating system. Gating system includes the runner, riser, pouring basin and gate etc. The following diagram shows all the elements of gating system after completing the molding process.

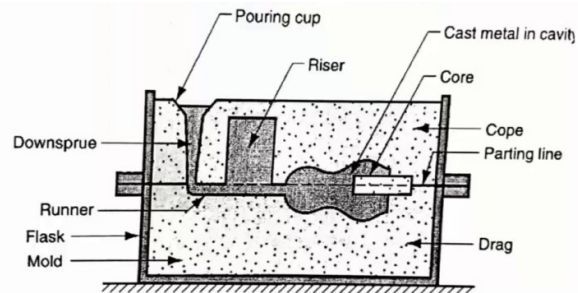

Elements of Gating System:

- **Pouring basin:** It is the conical hollow element or tapered hollow vertical portion of the gating system which helps to feed the molten metal initially through the path of gating system to mould cavity. It makes easier for the ladle operator to direct the flow of molten metal from crucible to pouring basin and sprue. It helps in maintaining the required rate of liquid metal flow. It reduces turbulence and vortexing at the sprue entrance. It also helps in separating dross, slag and foreign element etc. from molten metal before it enters the sprue.
- **Sprue:** It is a vertical passage made generally in the cope using tapered sprue pin. It is connected at bottom of pouring basin. It is tapered with its bigger end at to receive the molten metal the smaller end is connected to the runner. It helps to feed molten metal without turbulence to the runner which in turn reaches the mould cavity through gate. It sometimes possesses skim bob at its lower end. The main purpose of skim bob is to collect impurities from molten metal and it does not allow them to reach the mould cavity through runner and gate.
- **Choke:** It is that part of the gating system which possesses smallest cross-section area. In choked system, gate serves as a choke, but in free gating system sprue serves as a choke.
- **Runner:** It is the horizontal channel which connects the sprue base to the gate for avoiding turbulence and gas entrapment.
- **Gate:** It is a small passage or channel being cut by gate cutter which connect runner with the mould cavity and through which molten metal flows to fill the mould cavity. It feeds the liquid metal to the casting at the rate consistent with the rate of solidification.
- **Riser:** It is a passage in molding sand made in the cope portion of the mould. Molten metal rises in it after filling the mould cavity completely. The molten metal in the riser compensates the shrinkage during solidification of the casting thus avoiding the shrinkage defect in the casting. It also permits the escape of air and mould gases. It promotes directional solidification too and helps in bringing the soundness in the casting.

Additional Accessories:

- **Chaplets:** Chaplets are metal pieces inserted in a mould either to prevent shifting of mould or locate core surfaces. Its main objective is to impart good alignment of mould and core surfaces and to achieve directional solidification. When the molten metal is poured in the mould cavity, the chaplet melts and fuses itself along with molten metal during solidification and thus forms a part of the cast material.
- **Chills:** In some casting, it is required to produce a hard surface at a particular place in the casting. At that particular position, the special mould surface for fast extraction of heat is to be made. The fast heat extracting metallic materials known as chills will be incorporated separately along with sand mould surface during molding. After pouring of molten metal and

during solidification, the molten metal solidifies quickly on the metallic mould surface in comparison to other mould sand surfaces.

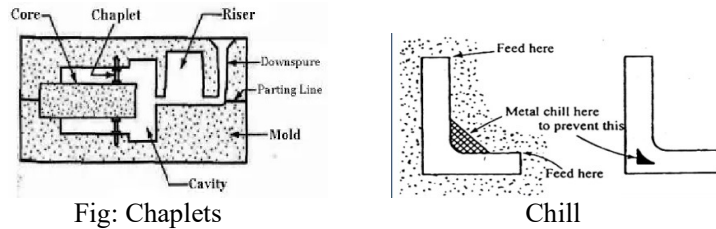

Function of an Ideal Gating System:

The main functions of an ideal gating system are to

- distribute the molten metal with the least disturbance in order to reduce erosion of the mould material.
- facilitate complete filling of the mould cavity.
- fill the mould cavity with molten metal at the earliest possible time to avoid temperature gradient.
- develop such temperature gradient in molten metal and the mould which will lead to the directional solidification of the casting towards riser.
- prevent the formation of oxide and dross in the molten metal while flowing through it.
- prevent the entry of slag, sand and the other particles from the mould.

Types of Gating systems:

Gating Ratio The gating ratio refers to the proportion of the cross-sectional area between the sprue, runner and ingate.

Generally it is denoted as Sprue area: Runner area: Ingate area

Depending on gating ratio, there are two types of gating systems are available.

1 Pressurized gating system

2 Un-pressurized gating system

Pressurized Gating System:

- ✓ The total cross sectional area decreases towards the mold cavity.
- ✓ The gating ratio of a typical pressurized gating system is
Sprue area: Runner area: Ingate area 1: 2: 1
- ✓ Back pressure is maintained by the restrictions in the metal flow.
- ✓ Back pressure helps in reducing the aspiration as the sprue always runs full.
- ✓ Because of the restrictions the metal flows at high velocity leading to more turbulence and chances of mold erosion.
- ✓ Because of the turbulence this type of gating system is not used for light alloys but can be advantageously used for ferrous castings.

Un-Pressurized Gating System:

- ✓ The total cross sectional area increases towards the mold cavity.
- ✓ The gating ration of a typical un-pressurized gating system is:
Sprue area: Runner area: Ingate area: 1: 4: 4
- ✓ Flow of liquid (volume) is different from all gates, aspiration in the gating system as the system never runs full
- ✓ Less turbulence, Because of less turbulence this type of gating system is used for light alloys such as aluminum and magnesium alloys.

The following diagram shows the difference between pressurized and un-pressurized system.

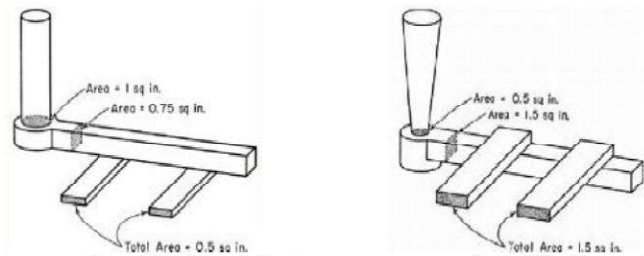

Types of Gates: As per their position in the mould cavity, gates may be classified as follows:

- **Parting Line Gate:** It is the simplest type of gate and the molten metal enters the mould cavity at the parting line. Such type of gate is cut by hand when the cope and drag are separated or it can be formed by an attached gate to the pattern.

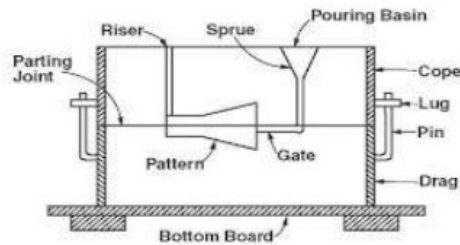

- **Top Gate:** In this type of gate, the molten metal from the top flows down directly into the mould. As all the molten metal enters the casting at the top therefore, the hottest metal comes to rest at the top of casting. With the result, proper temperature gradient is formed to enable directional solidification of casting from the bottom side towards the riser. The gates themselves may be cut to serve as the risers. Main drawback of this type of gating is the erosion of the mould, which takes place by the falling metal. The cavity of mould, therefore, should be much hard and strong to resist this impact.

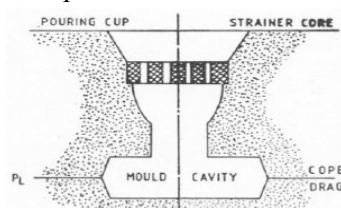

- **Bottom Gate:** In this type of gate, the molten metal from the pouring basin flows down and enters to the mould cavity at or near its bottom. Bottom type of gate facilitates the mould to be prepared in two molding boxes. During pouring of molten metal, bottom types of gate enable to reduce the erosion of mould and core and minimize the turbulence of metal.

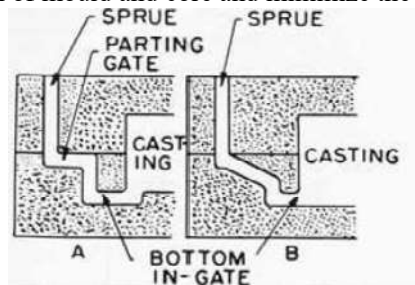

Gating & Riser Design:

A well designed gating system and riser ensures the smooth, uniform and complete filling of clean molten metal. Clean metal implies preventing the entry of slag and inclusions into the mould cavity which minimizes the surface turbulence. Hence, proper design of gating system and riser results in quality casting. The yield Percentage (**Casting Yield**) per component is given as:

$$\text{Cast Yield\%} = \left(\frac{\text{Volume cast}}{\text{Volume cast} + \text{Volume gating riser}} \right) \times 100$$

- **Design of Gating Elements:**

- ✓ **Pouring cup:** It is circular or rectangular in shape. In order that the metal enters into the sprue without any turbulence it is necessary that the pouring basin be deep, also the entrance into the sprue is a smooth radius of at least 25mm. The recommended pouring cup depth 2.5 times the sprue entrance diameter is enough for smooth metal flow and to prevent vortex formation.

- ✓ **Sprue:** The sprue should be a vertical taper passage through the cope to gain the velocity of the metal as it flows down reducing the air aspiration and connecting the pouring basin to the runner. The taper can obtain by the continuity equation.

$$A_t V_t = A_c V_c$$

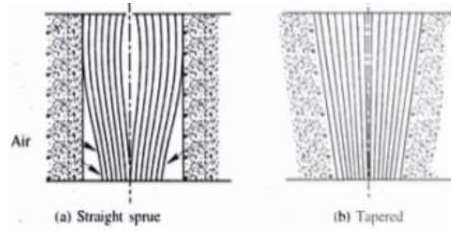

The velocities are proportional to the square of the potential head. $A_t = A_c \sqrt{\left(\frac{ht}{hc}\right)}$

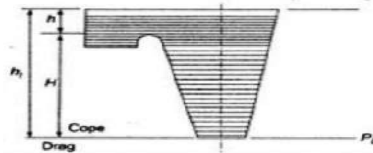

Where $h = H - h_t$
 $H =$ Actual sprue height mm

Riser Design:

- ✓ Riser is basically additional reservoir of molten metal which is used to compensate for liquid shrinkage and solidification shrinkage.
- ✓ To fulfill this function molten metal in the riser should solidify latter than the molten metal in the casting. That means solidification time of the metal in the riser must be longer than the solidification time of the metal in the mould.

Types of Risers: A riser is categorized based on three criteria: where it is located, whether it is open to the atmosphere, and how it is filled.

- ✓ If the riser is located on the casting then it is known as a top riser, but if it is located next to the casting it is known as a side riser.
- ✓ Top risers are advantageous because they take up less space in the flask than a side riser, plus they have a shorter feeding distance. If the riser is open to the atmosphere it is known as an open riser, but if the riser is completely contained in the mold it is known as a blind riser. An open riser is usually bigger than a blind because the open riser loses more heat to mold through the top of the riser.

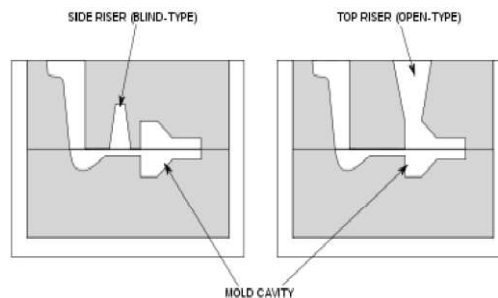

- ✓ Finally, if the riser receives material from the gating system and fills before the mold cavity it is known as a live riser or hot riser. If the riser fills with material that has already flowed through the mold cavity it is known as a dead riser or cold riser. Live risers are usually smaller than dead risers. Top risers are almost always dead risers and risers in the gating system are almost always live risers.

Design Requirements of Risers

- ✓ 1. Riser placement: the spacing of risers in the casting must be considered by effectively calculating the feeding distance of the risers.
- ✓ 2. Riser shape: cylindrical risers are recommended for most of the castings as spherical risers, although considers as best, are difficult to cast. To increase volume/surface area ratio the

bottom of the riser can be shaped as hemisphere also and the most important rule is riser solidification time must be longer than casting solidification time by Chvorinov's rule.

$$T_{Riser} = K \left(\frac{V_{Riser}}{SA_{Riser}} \right)^n$$

$$T_{Riser} > T_{Casting}$$

Riser Shape:

1. Cylindrical
 2. Spherical (Ideal) impossible by Manufacture (Hemi-Spherical Actually)
- **Caine's method:** This method is based on the relative freezing time of the casting and the riser. According to caine:
1. If the casting solidifies infinitely rapidly the feeder or riser volume should be equal to the solidification shrinkage of the casting.
 2. If the feeder and casting solidify at the same rate the feeder should be infinitely large.
- Caine's formula for calculate freezing time:

$$X = \frac{a}{Y - b} + c$$

Where X = Freezing ratio, [surface area/volume] of casting to [surface area/volume] of riser
a = Freezing characteristics constant for the metal
Y = Ratio of riser volume by casting volume
b = contraction ratio from liquid to solid
c = relative freezing ratio of riser and casting.

According to the curve shown if the intersecting point of X and Y fall above the curve the casting would be a sound one or it results in a defective casting. To determine the diameter and height of the cylindrical riser, X, Y and other constants must be substituted in the Cain's equation which gives a polynomial equation interms of the parameter, D the diameter of the riser. By taking the D/H ratio of the riser height of the riser can be obtained.

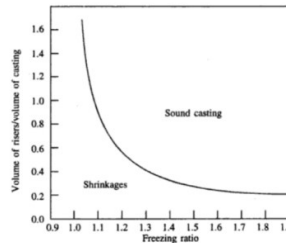

- **Modulus method:** Modulus is defined as the ratio of the volume to surface area. If the riser has to feed the casting, modulus of the riser must be greater than the modulus of the casting. It is observed that if modulus of the riser is greater than the casting by 1.2 times then feeding would be proper. Based on this relation and appropriate D/H ratio riser would be designed.
- **NRLMethod:** NRL stands for Naval Research Laboratory. This is a simplified form of caine's method. In this method shape factor is used in place of freezing ratio.

$$\text{Where shape factor} = \frac{\text{Length} + \text{Width}}{\text{Thickness}}$$

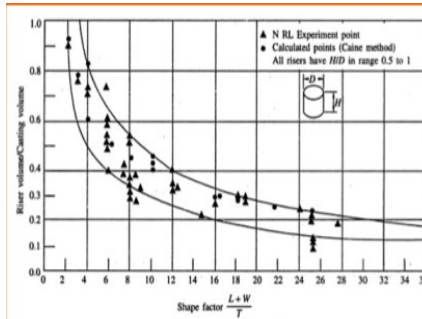

Riser Location: To determine the correct riser location, the methods engineer must make use of the concept of directional solidification. If shrinkage cavities in the casting are to be avoided, solidification should proceed directionally from those parts of the casting farthest from the riser, through the intermediate portions of the casting, and finally into the riser itself, where the final solidification will occur. Shrinkage at each step of solidification is thus fed by liquid feed metal being drawn out of the riser.

Feeding Distance of Riser: The feeding distance (FD) is the maximum distance over which a riser can supply feed metal such that the casting section remains relatively free of internal porosity. Hence, the feeding distance determines the number of risers needed. The feeding distance is always measured from the edge of the riser to the furthest point in the casting section to be fed by that riser. This is illustrated for a plate with a top riser and for a plate with a side riser in Figure.

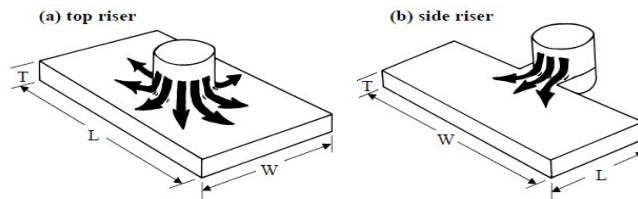

Now if we take this casting, it is a plate type of the structure. So, in this case what we see is the distance which is shown this is basically the maximum distance which it can feed, that is $4.5 T$. T is the thickness of this plate.

There are two terms that are important to understand when considering feeding distances: riser zone and end zone.

- The length over which this riser effect acts to prevent shrinkage porosity is called the riser zone length (RZL). This is illustrated for a top riser in Figure.
- The cooling effect of the mold at the end of a casting section also provides a temperature gradient along the length of the casting section to be fed. This is called the end effect, and it produces a sound casting over the so-called end zone length (EZL). This is depicted in Figure.

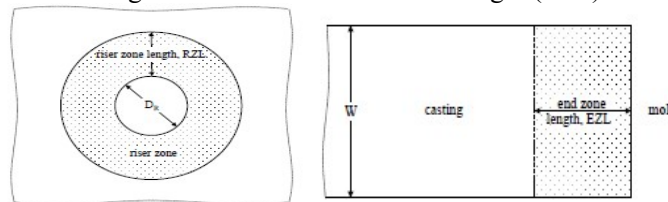

Design considerations in casting:

1. Design the part so that the shape is cast easily.
2. Select a casting process and material suitable for the part, size, mechanical properties, etc.
3. Locate the parting line of the mold in the part.
4. Locate and design the gates to allow uniform feeding of the mold cavity with molten metal.
5. Select appropriate runner geometry for the system.
6. Locate mold features such as sprue, screens and risers, as appropriate.

7. Make sure proper controls and good practices are in place.
8. Corners, angles and section thickness: avoid using sharp corners and angles (act as stress raisers) and may cause cracking and tearing during solidification. Use fillets with radii ranging from 3 to 25 mm

Solidification: Solidification involves the transformation of the molten metal back into the solid state. The solidification process differs depending on whether the metal is a pure element or an alloy. A pure metal solidifies at a constant temperature equal to its freezing point, which is the same as its melting point. Most alloys freeze over a temperature range rather than at a single temperature. The exact range depends on the alloy system and the particular composition.

Solidification Time: Whether the casting is pure metal or alloy, solidification takes time. The total solidification time is the time required for the casting to solidify after pouring. This time is dependent on the size and shape of the casting by an empirical relationship known as Chvorinov's rule, which states:

$$T = K \left(\frac{V}{SA} \right)^n$$

Where T= total solidification time, min, V= volume of the casting, cm³; SA=surface area of the casting, cm²; n is an exponent usually taken to have a value 2; and K is the mold constant.

Types of solidification: (i) Directional Solidification (ii) Progressive Solidification

Directional Solidification: Directional solidification is solidification that occurs from farthest end of the casting and works its way towards the sprue.

Progressive Solidification: Progressive solidification, also known as parallel solidification, is solidification that starts at the walls of the casting and progresses perpendicularly from that surface.

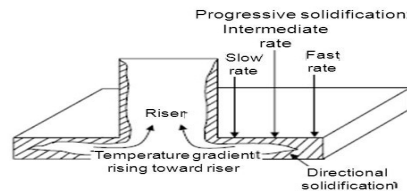

Sample Problem on solidification time:

1. With a solidification factor of $0.97 \times 10^6 \text{ sec}^2/\text{m}^2$, solidification time (in seconds) for a spherical casting of 200 mm diameter is _____ (Sol: 1078 sec)
2. Two castings, a cube and a slab of the same material solidify under identical conditions. The volumes of the castings are equal but the slab dimensions are in the ratio 1:2:4. Find the ratio of solidification time of cube to the slab. (Sol: 14/13)
3. Two solid workpiece: (i) a sphere with a radius R (ii) cylinder with diameter equal to its height, have to be sand cast. Both work pieces have the same volume. Show that the cylindrical workpiece will solidify faster than spherical workpiece.
4. In the casting of steel under certain mold conditions, the mold constant in Chvorinov's Rule is known to be $C_m = 4.0 \text{ min}/\text{cm}^2$, based on previous experience. The casting is a flat plate whose length = 30 cm, width = 10 cm, and thickness = 20 mm. Determine how long it will take for the casting to solidify. (Sol: 2.49 min)
5. A disk-shaped part is to be cast out of aluminum. The diameter of the disk = 500 mm and its thickness = 20 mm. If $C_m = 2.0 \text{ sec}/\text{mm}^2$ in Chvorinov's Rule, how long will it take the casting to solidify? (Sol: 2.86 min)

Sample problems on riser design:

1. A cylindrical riser is to be used for a sand casting mold. For a given cylinder volume, determine the diameter-to-length ratio that will maximize the time to solidify. (Sol: optimal D/L ratio = 1.0)
2. A riser in the shape of a sphere is to be designed for a sand casting mold. The casting is a rectangular plate, with length = 200 mm, width = 100 mm, and thickness = 18 mm. If the total solidification time of the casting itself is known to be 3.5 min, determine the diameter of the riser so that it will take 25% longer for the riser to solidify. (Sol: D = 47.5 mm)

3. A cylindrical riser is to be designed for a sand casting mold. The length of the cylinder is to be 1.25 times its diameter. The casting is a square plate, each side = 10 mm and thickness = 0.75 mm. If the metal is cast iron, and $C_m = 16.0 \text{ min/mm}^2$ in Chvorinov's Rule, determine the dimensions of the riser so that it will take 30% longer for the riser to solidify.
4. A cylindrical riser must be designed for a sand-casting mold. The casting itself is a steel rectangular plate with dimensions 7.5cmX12.5cmX2.0cm. Previous observations have indicated that the total solidification time (TTS) for this casting = 1.6 min. The cylinder for the riser will have a diameter-to-height ratio = 1.0. Determine the dimensions of the riser so that its TTS = 2.0 min.

SPECIAL CASTING PROCESSES

Centrifugal Casting: Centrifugal casting refers to several casting methods in which the mold is rotated at high speed so that centrifugal force distributes the molten metal to the outer regions of the die cavity.

The group includes (1) true centrifugal casting, (2) semi centrifugal casting, and (3) centrifuge casting.

- ✓ **True Centrifugal Casting:** In true centrifugal casting, molten metal is poured into a rotating mold to produce a tubular part. Examples of parts made by this process include pipes, tubes, bushings, and rings. The simple set up of it as shown in figure. Molten metal is poured into a horizontal rotating mold at one end. In some operations, mold rotation commences after pouring has occurred rather than beforehand. The high-speed rotation results in centrifugal forces that cause the metal to take the shape of the mold cavity. Thus, the outside shape of the casting can be round, octagonal, hexagonal, and so on. However, the inside shape of the casting is (theoretically) perfectly round, due to the radially symmetric forces at work. Orientation of the axis of mold rotation can be either horizontal or vertical.

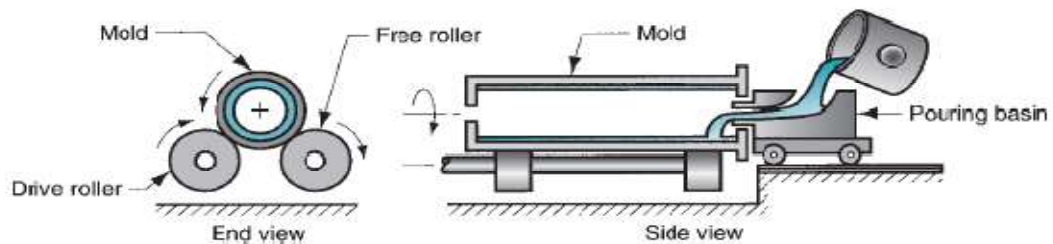

Semi centrifugal Casting: In this method, centrifugal force is used to produce solid castings, as in Figure, rather than tubular parts. The molds are designed with risers at the center to supply feed metal. Density of metal in the final casting is greater in the outer sections than at the center of rotation. The process is often used on parts in which the center of the casting is machined away, thus eliminating the portion of the casting where the quality is lowest. Wheels and pulleys are examples of castings that can be made by this process. Expendable molds are often used in semi centrifugal casting, as suggested by our illustration of the process.

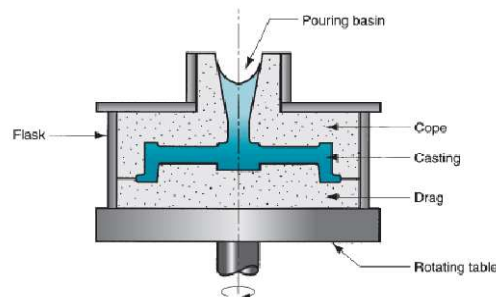

Centrifuge Casting: In centrifuge casting, the mold is designed with part cavities located away from the axis of rotation, so that the molten metal poured into the mold is distributed to these cavities by centrifugal force. The process is used for smaller parts, and radial symmetry of the part is not a

requirement as it is for the other two centrifugal casting methods. Set up of centrifugal casting is as shown in figure.

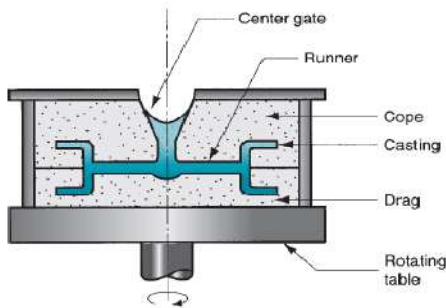

Investment Casting:

- ✓ In investment casting, a pattern made of wax is coated with a refractory material to make the mold, after which the wax is melted away prior to pouring the molten metal. Investment casting uses a piece of ceramic mould.
- ✓ The mould is prepared by surrounding the ceramic material over the wax or plastic pattern. Once the ceramic material solidifies, the wax replica is melted and drained out from the mould and the metal is poured into the mould cavity.
- ✓ It is a precision casting process, because it is capable of making castings of high accuracy and intricate detail. It is also known as the lost-wax process, because the wax pattern is lost from the mold prior to casting.
- ✓ **Steps in investment casting:**
 - (1) Wax patterns are produced;
 - (2) Several patterns are attached to a sprue to form a pattern tree.
 - (3) The pattern tree is coated with a thin layer of refractory material.
 - (4) The full mold is formed by covering the coated tree with sufficient refractory material to make it rigid.
 - (5) The mold is held in an inverted position and heated to melt the wax and permit it to drip out of the cavity.
 - (6) The mold is preheated to a high temperature, which ensures that all contaminants are eliminated from the mold; it also permits the liquid metal to flow more easily into the detailed cavity; the molten metal is poured; it solidifies.
 - (7) The mold is broken away from the finished casting. Parts are separated from the sprue.
- ✓ The basic steps involved in investment casting are as shown in figure.

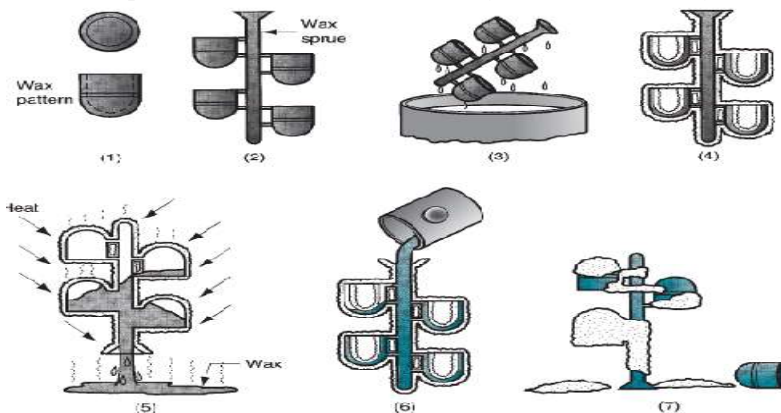

Die casting: Die casting is a permanent-mold casting process in which the molten metal is injected into the mold cavity under high pressure.

Die casting is a manufacturing process that can produce geometrically complex metal parts through the use of reusable molds, called dies, hence the name die casting.

This process is a further development of Permanent – mold casting. A permanent mold casting process in which molten metal is injected into mold cavity under high pressure, typical pressures are

(7 to 350 MPa). Pressure is maintained during solidification, then mold is opened and part is removed.

Use of high pressure to force metal into die cavity is what distinguishes this from other permanent mold processes.

Steps of Die Casting: There are four key steps in the process of die casting, the die casting machine should be at the required temperature, to ensure the molten metal not to solidify too quickly. According to the size of the casting, heating can take from several hours to several minutes.

✓ The four steps are:

- 1) Spray the mold with lubricant and close it, allowing for an easier removal of the cast object later on.
- 2) Inject the molten metal into the die. The metal is inserted at an extremely high pressure, which allows the metal to conform to the precise shape of the die.
- 3) Cool the mold, and wait for the metal to solidify. In some cases, the mold may be immersed or sprayed with cold water to help the casting become solid faster. A high pressure is maintained inside the mold, which ensures the metal doesn't change properties while inside the die.
- 4) Open the die and remove the solid cast.

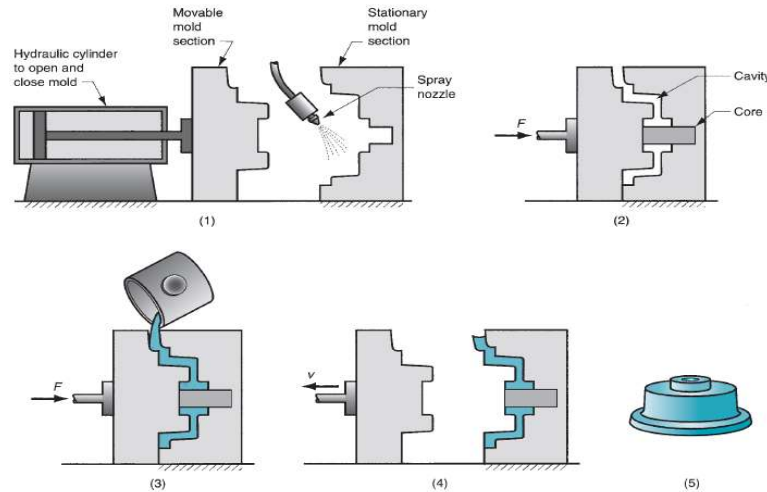

✓ Die casting is categorized two types namely- hot chamber and cold chamber.

Hot-Chamber Die Casting:

- ❖ Metal is melted in a container, and a piston injects liquid metal under high pressure into the die.
- ❖ High production rates - 500 parts per hour not uncommon.
- ❖ Applications limited to low melting-point metals that do not chemically attack plunger and other components due to the hot metal that is poured in to them.
- ❖ Casting metals: zinc, tin, lead, and magnesium.

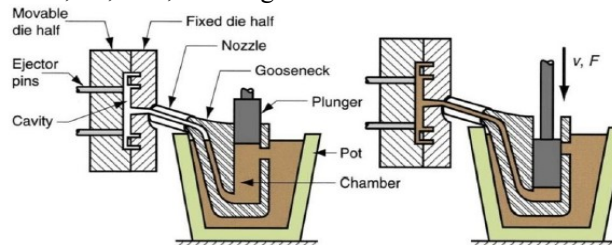

Cold Chamber Die Casting Machine:

- ❖ Molten metal is poured into unheated chamber from external melting container (ladle), and a piston injects metal under high pressure into die cavity at pressure as much as (10 times) than that in the Hot – Chamber process.
- ❖ High production but not usually as fast as hot-chamber machines because of pouring step Casting metals: aluminum, brass, and magnesium alloys.

- ❖ With die closed and ram withdrawn, molten metal is poured into the chamber.
- ❖ Ram forces metal to flow into die, maintaining pressure during cooling and solidification.

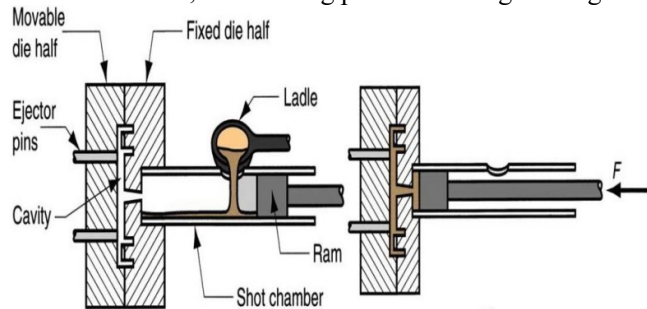

Shell Mold Casting:

- ✓ Shell mold casting or shell molding is a metal casting process in manufacturing industry in which the mold is a thin hardened shell of sand and thermosetting resin binder backed up by some other material.
- ✓ Shell mold casting is particularly suitable for steel castings under 10 kg; Typical parts manufactured in industry using the shell mold casting process include cylinder heads, gears, bushings, connecting rods, camshafts and valve bodies.

✓ Steps in shell molding:

1. The first step in the shell mold casting process is to manufacture the shell mold.
2. The fine grained sand is mixed with a thermosetting resin binder. A special metal pattern is coated with a parting agent; (typically silicone), which will later facilitate in the removal of the shell. The metal pattern is then heated to a temperature of (175 °C-370 °C)
3. The sand mixture is then poured or blown over the hot casting pattern. Due to the reaction of the thermosetting resin with the hot metal pattern a thin shell forms on the surface of the pattern. The desired thickness of the shell is dependent upon the strength requirements of the mold for the particular metal casting application.
4. A typical industrial manufacturing mold for a shell molding casting process could be 7.5mm thick. The thickness of the mold can be controlled by the length of time the sand mixture is in contact with the metal casting pattern.
5. The excess "loose" sand is then removed leaving the shell and pattern. The shell and pattern are then placed in an oven for a short period of time, (minutes), which causes the shell to harden onto the casting pattern.
6. Once the baking phase of the manufacturing process is complete the hardened shell is separated from the casting pattern by way of ejector pins built into the pattern.
7. Two of these hardened shells, each representing half the mold for the casting are assembled together either by gluing or clamping. The manufacture of the shell mold is now complete and ready for the pouring of the metal casting. In many shell molding processes the shell mold is supported by sand or metal shot during the casting process.

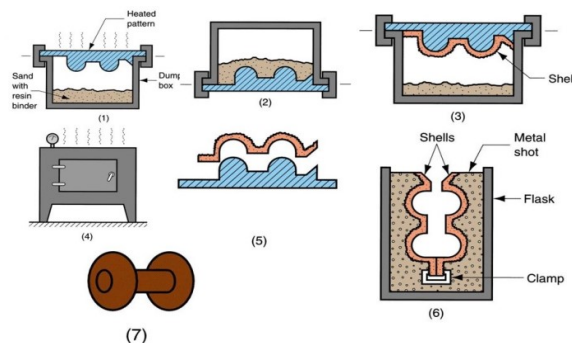

Slush Casting: Slush Casting is a traditional method of permanent mold casting process, where the molten metal is not allowed to completely solidify in the mold. When the desired thickness is obtained, the remaining molten metal is poured out. Slush casting method is an effective technique to cast hollow items like decorative pieces, components, ornaments, etc.

- Steps in Slush Casting:
- Firstly, a pattern is made using plaster or wood. Now the pattern is placed on a cardboard or wooden board. A mold box is kept around the pattern. The unwanted space that is formed in the mold box can be eliminated by placing a board. Once the pattern is set the molding material is poured on the pattern and allowed to set with the molding aggregate. When the mold is set, the pattern is withdrawn from the mold.

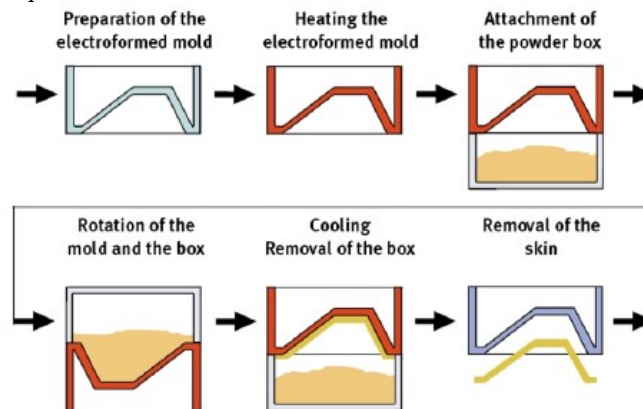

Casting Defects: Casting defects can be categorized into 5 types

1. **Gas Porosity:** Blowholes, open holes, pinholes
2. **Shrinkage defects:** shrinkage cavity
3. **Mold material defects:** Cut and washes, swell, drops, metal penetration, rat tail
4. **Pouring metal defects:** Cold shut, misrun, slag inclusion
5. **Metallurgical defects:** Hot tears, hot spot.

1. Shift or Mismatch: The defect caused due to misalignment of upper and lower part of the casting and misplacement of the core at parting line.

Cause:

- (i) Improper alignment of upper and lower part during mold preparation.
- (ii) Misalignment of flask (a flask is type of tool which is used to contain a mold in metal casting. it may be square, round, rectangular or of any convenient shape.)

Remedies

- (i) Proper alignment of the pattern or die part, molding boxes.
- (ii) Correct mountings of pattern on pattern plates.
- (iii) Check the alignment of flask.

2. Swell: It is the enlargement of the mold cavity because of the molten metal pressure, which results in localised or overall enlargement of the casting.

Causes: Defective or improper ramming of the mold.

Remedies: The sand should be rammed properly and evenly.

3. Blowholes: When gases entrapped on the surface of the casting due to solidifying metal, a rounded or oval cavity is formed called as blowholes. These defects are always present in the cope part of the mold.

Causes:

- (i) Excessive moisture in the sand.
- (ii) Low Permeability of the sand.
- (iii) Sand grains are too fine.
- (iv) Too hard rammed sand.
- (v) Insufficient venting is provided.

Remedies:

- (i) The moisture content in the sand must be controlled and kept at desired level.
- (ii) High permeability sand should be used.
- (iii) Sand of appropriate grain size should be used.
- (iv) Sufficient ramming should be done.
- (v) Adequate venting facility should be provided.

4. Drop: Drop defect occurs when there is cracking on the upper surface of the sand and sand pieces fall into the molten metal.

Causes:

- (i) Soft ramming and low strength of sand.
- (ii) Insufficient fluxing of molten metal. Fluxing means addition of a substance in molten metal to remove impurities. After fluxing the impurities from the molten metal can be easily removed.
- (iii) Insufficient reinforcement of sand projections in the cope.

Remedies:

- (i) Sand of high strength should be used with proper ramming (neither too hard nor soft).
- (ii) There should be proper fluxing of molten metal, so the impurities present in molten metal is removed easily before pouring it into the mold.
- (iii) Sufficient reinforcement of the sand projections in the cope.

5. Metal Penetration: These casting defects appear as an uneven and rough surface of the casting. When the size of sand grains is large, the molten metal fuses into the sand and solidifies giving us metal penetration defect.

Causes: It is caused due to low strength, large grain size, high permeability and soft ramming of sand. Because of this the molten metal penetrates in the molding sand and we get rough or uneven casting surface.

Remedies: This defect can be eliminated by using high strength, small grain size, low permeability and soft ramming of sand.

6. Pinholes: They are very small holes of about 2 mm in size which appears on the surface of the casting. This defect happens because of the dissolution of the hydrogen gases in the molten metal. When the molten metal is poured in the mold cavity and as it starts to solidify, the solubility of the hydrogen gas decreases and it starts escaping out the molten metal leaves behind small number of holes called as pinholes.

Causes

- (i) Use of high moisture content sand.
- (ii) Absorption of hydrogen or carbon monoxide gas by molten metal.
- (iii) Pouring of steel from wet ladles or not sufficiently gasified.

Remedies

- (i) By reducing the moisture content of the molding sand.
- (ii) Good fluxing and melting practices should be used.
- (iii) Increasing permeability of the sand.
- (iv) By doing rapid rate of solidification.

7. Shrinkage Cavity: The formation of cavity in the casting due to volumetric contraction is called as shrinkage cavity.

Causes

- (i) Uneven or uncontrolled solidification of molten metal.
- (ii) Pouring temperature is too high.

Remedies

- (i) This defect can be removed by applying principle of directional solidification in mold design.
- (ii) Wise use of chills (a chill is an object which is used to promote solidification in a specific portion of a metal casting) and padding.

8. Cold Shut:It is a type of surface defects and a line on the surface can be seen. When the molten metal enters into the mold from two gates and when these two streams of molten metal meet at a junction with low temperatures than they do not fuse with each other and solidifies creating a cold shut (appear as line on the casting). It looks like a crack with round edge.

Causes

- (i) Poor gating system
- (ii) Low melting temperature
- (iii) Lack of fluidity

Remedies

- (i) Improved gating system.
- (ii) Proper pouring temperature.

9. Misrun:When the molten metal solidifies before completely filling the mold cavity and leaves a space in the mold called as misrun.

Causes

- (i) Low fluidity of the molten metal.
- (ii) Low temperature of the molten metal which decreases its fluidity.
- (iii) Too thin section and improper gating system.

Remedies

- (i) Increasing the pouring temperature of the molten metal increases the fluidity.
- (ii) Proper gating system
- (iii) Too thin section is avoided.

10. Slag Inclusion:This defect is caused when the molten metal containing slag particles is poured in the mold cavity and it gets solidifies.

Causes: The presence of slag in the molten metal

Remedies: Remove slag particles form the molten metal before pouring it into the mold cavity.

11. Hot Tears or Hot Cracks: When the metal is hot it is weak and the residual stress (tensile) in the material cause the casting fails as the molten metal cools down. The failure of casting in this case is looks like cracks and called as hot tears or hot cracking.

Causes: Improper mold design.

Remedies

- (i) Proper mold design can easily eliminate these types of casting defects.
- (ii) Elimination of residual stress from the material of the casting.

12. Hot Spot or Hard Spot:Hot spot defects occur when an area on the casting cools more rapidly than the surrounding materials. Hot spot are areas on the casting which is harder than the surrounding area. It is also called as hard spot.

Causes: The rapid cooling an area of the casting than the surrounding materials causes this defect.

Remedies

- (i) This defect can be avoided by using proper cooling practice.
- (ii) By changing the chemical composition of the metal.

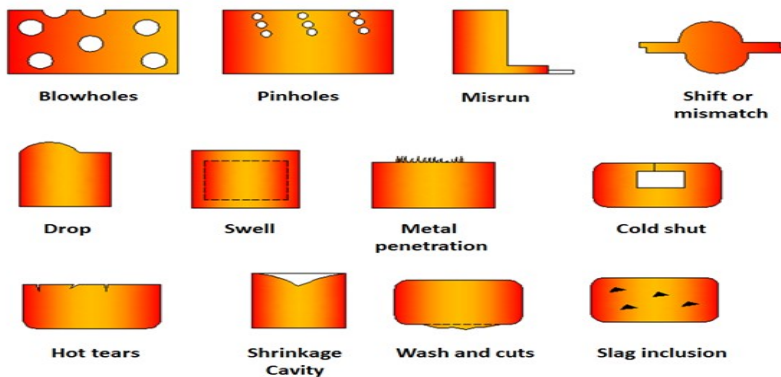

METAL JOINING PROCESSES

Introduction:

Definition: “Metal joining is defined as joining of two metal parts either temporarily or permanently with or without the application of heat or pressure. “

Note: Joining (welding): positive process

- The term joining is generally used for welding, brazing, soldering, and adhesive bonding, which form a permanent joint between the parts—a joint that cannot easily be separated.
- The term assembly usually refers to mechanical methods of fastening parts together.

Classification of joining processes:

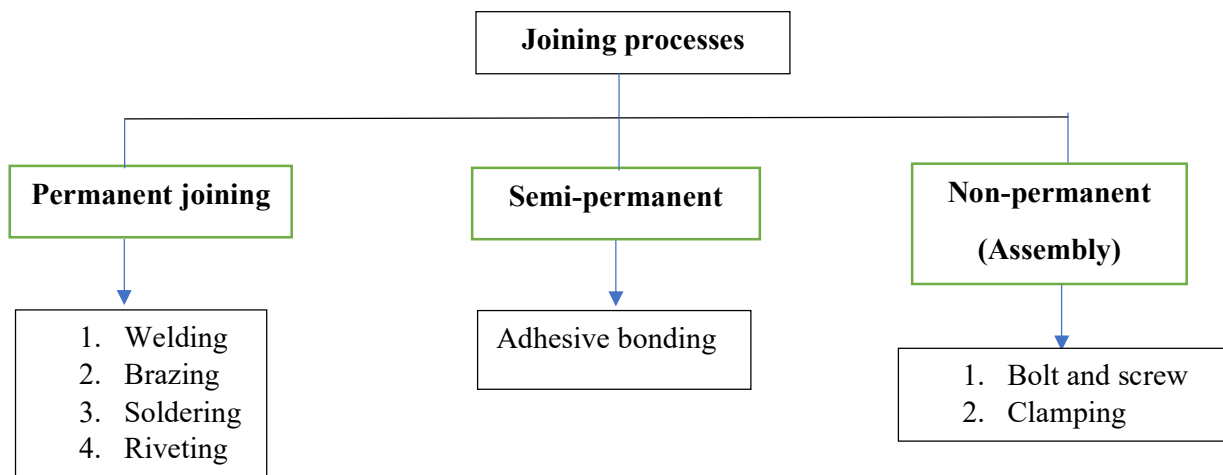

WELDING

Definition: “Welding is a material joining process in which two or more parts are coalesced at their contacting surfaces by a suitable application of heat and/or pressure, with or without filler material. “

Advantages and Disadvantages of Welding:

Advantages: -

1. Permanent joint is produced, which becomes an integral part of work piece.
2. Joints can be stronger than the base metal if good quality filler metal is used.
3. Economical method of joining.
4. It is not restricted to the factory environment.

Disadvantages: -

1. Labour cost is high as only skilled welder can produce sound and quality weld joint.
2. It produces a permanent joint which in turn creates the problem in disassembling if of sub-component required.

3. Hazardous fumes and vapours are generated during welding. This demand proper ventilation of welding area.
4. Weld joint itself is considered as a discontinuity owing to variation in its structure, composition and mechanical properties; therefore, welding is not commonly recommended for critical application where there is a danger of life.

Classification of Welding Processes:

Welding processes can be classified based on following technological criteria:

- Welding with or without filler material
- Source of energy for welding
- Arc and non-arc welding
- Fusion and pressure welding

Welding with or without filler material: -

A weld joint can be developed just by melting of edges (faying surfaces) of plates or sheets to be welded especially when thickness is lesser than 5 mm thickness.

Following are typical welding processes in which filler metal is generally not used to produce a weld joint.

- ✓ Laser beam welding
- ✓ Electron beam welding
- ✓ Resistance welding
- ✓ Friction stir welding

However, for welding of thick plates/sheets using any of the following processes filler metal can be used as per needs according to thickness of plates. Following are few fusion welding processes where filler may or may not be used for developing weld joints:

- ✓ Plasma arc welding
- ✓ Gas tungsten arc welding
- ✓ Gas welding

Some of the welding processes are inherently designed to produce a weld joint by applying heat for melting base metal and filler metal both. These processes are mostly used for welding of thick plates (usually > 5mm) with comparatively higher deposition rate.

- ✓ Metal inert gas welding: (with filler)
- ✓ Submerged arc welding: (with filler)
- ✓ Flux cored arc welding: (with filler)
- ✓ Electro gas/slag welding: (with filler)

Source of energy for welding: -

Based on the type of energy being used for creating metallic bonds between the components to be welded, welding processes can be grouped as under:

- ✓ Chemical energy: Gas welding, explosive welding, thermite welding
- ✓ Mechanical energy: Friction welding, ultrasonic welding
- ✓ Electrical energy: Arc welding, resistance welding
- ✓ Radiation energy: Laser beam welding, electron beam welding

Arc or Non-arc welding: -

All those welding processes in which heat for melting the faying surfaces is provided after establishing an arc either between the base plate and an electrode or between electrode & nozzle are grouped under arc welding processes.

Another set of welding processes in which metallic bond is produced using pressure or heat generated from sources other than arc namely chemical reactions or frictional effect

etc., are grouped as non-arc-based welding processes. Welding processes corresponding to each group are given below.

Arc based welding processes: -

- ✓ Shielded Metal Arc Welding: Arc between base metal and covered electrode.
- ✓ Gas Tungsten Arc Welding: Arc between base metal and tungsten electrode.
- ✓ Plasma Arc Welding: Arc between base metal and tungsten electrode.
- ✓ Gas Metal Arc Welding: Arc between base metal and consumable electrode.
- ✓ Flux Cored Arc Welding: Arc between base metal and consumable electrode.
- ✓ Submerged Arc Welding: Arc between base metal and consumable electrode.

Non-arc-based welding processes: -

- ✓ Resistance welding processes: uses electric resistance heating.
- ✓ Gas welding: uses heat from exothermic chemical reactions.
- ✓ Thermit welding: uses heat from exothermic chemical reactions.
- ✓ Ultrasonic welding: uses both pressure and frictional heat.
- ✓ Diffusion welding: uses electric resistance/induction heating to facilitate diffusion.
- ✓ Explosive welding: involves pressure.

Pressure or Fusion welding: -

Welding processes in which heat is primarily applied for melting of the faying surfaces are called fusion welding processes while other processes in which pressure is primarily applied (with little or no application of heat for softening of metal up to plastic state) for developing metallic bonds are termed as solid-state welding processes.

Pressure welding: -

- ✓ Resistance welding processes (spot, seam, projection, flash butt, arc stud welding)
- ✓ Ultrasonic welding
- ✓ Diffusion welding
- ✓ Explosive welding

Fusion welding process: -

- ✓ Gas Welding
- ✓ Shielded Metal Arc Welding
- ✓ Gas Metal Arc Welding
- ✓ Gas Tungsten Arc Welding
- ✓ Submerged Arc Welding
- ✓ Electro Slag/Electro Gas Welding

NOTE: -There are many ways to classify the welding processes however, fusion welding and pressure welding criterion is the best and most accepted way to classify all the welding processes.

WELDING TERMINOLOGY: The following two figures (Fig 1, Fig 2) gives the details of various terms related to welding.

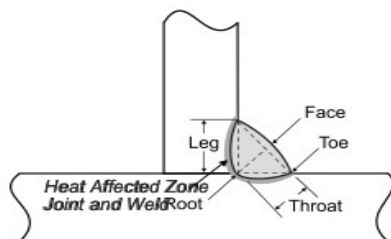

Fig 1: Fillet Weld Terminology

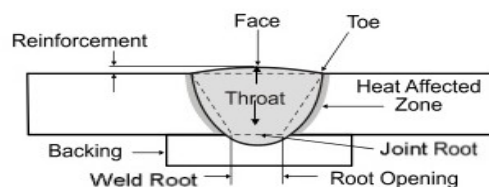

Fig 2: Groove Weld Terminology

Types of weld joints: -

Welding produces a solid connection between two pieces, called a weld joint. A weld joint is the junction of the edges or surfaces of parts that have been joined by welding. There are five basic types of weld joints. They are

- (a) **Butt joint:** In this joint type, the parts lie in the same plane and are joined at their edges.
- (b) **Corner joint:** The parts in a corner joint form a right angle and are joined at the corner of the angle.
- (c) **Lap joint:** This joint consists of two overlapping parts.
- (d) **Tee joint:** In a tee joint, one part is perpendicular to the other in the approximate shape of the letter “T.”
- (e) **Edge joint:** The parts in an edge joint are parallel with at least one of their edges in common, and the joint is made at the common edge(s).

The simple schematic representation of weld joint is shown in Fig 3.

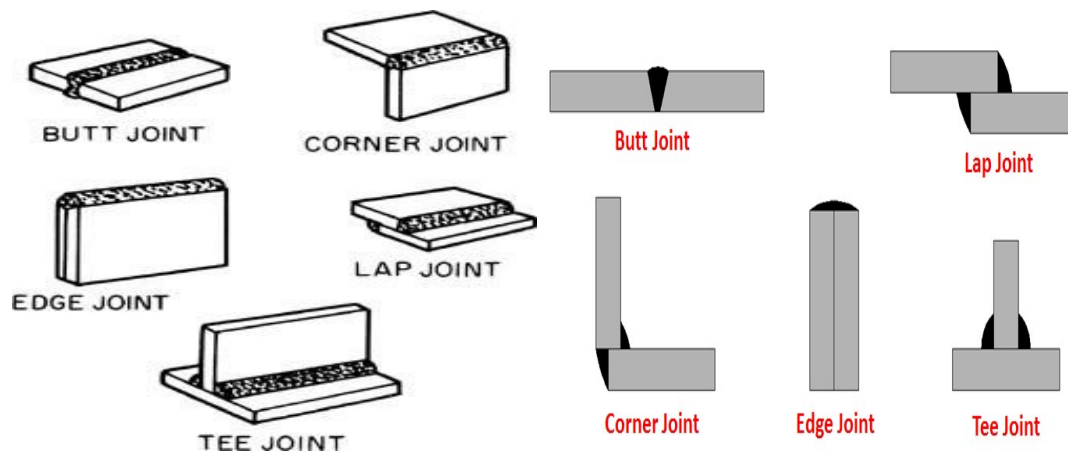

Fig 3: Types of Weld Joint

Types of welds:

Each of the preceding joints can be made by welding. It is appropriate to distinguish between the joint type and the way in which it is welded—the weld type. Differences among weld types are in geometry (joint type) and welding process.

- (a) A fillet weld is used to fill in the edges of plates created by corner, lap, and tee joints.
- (b) Groove welds usually require that the edges of the parts be shaped into a groove to facilitate weld penetration. The grooved shapes include square, bevel, V, U, and J, in single or double sides.
- (c) Plug welds and slot welds are used for attaching flat plates, using one or more holes or slots in the top part and then filling with filler metal to fuse the two parts together.
- (d) Spot welds and seam welds, used for lap joints, spot weld is a small fused section between the surfaces of two sheets or plates. Multiple spot welds are typically required to join the parts. It is most closely associated with resistance welding. A

seam weld is like a spot weld except it consists of a continuously fused section between the two sheets or plates. The representation of various welds is as shown in Fig 4& 5.

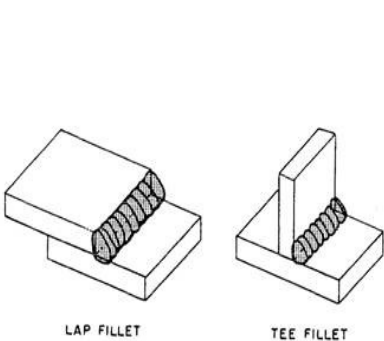

Fig 4: Fillet Weld

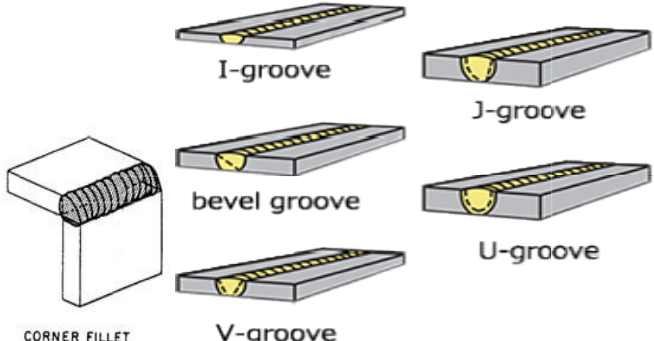

Fig 5: Groove Weld

FUSION WELDING

Fusion Welding Fusion-welding processes use heat to melt the base metals. In many fusion welding operations, a filler metal is added to the molten pool to facilitate the process and provide bulk and strength to the welded joint. The following are the most common type of fusion welding processes.

Oxy fuel gas welding (OFW): These joining processes use an oxy fuel gas, such as a mixture of oxygen and acetylene, to produce a hot flame for melting the base metal and filler metal, if one is used.

Arc welding (AW): Arc welding refers to a group of welding processes in which heating of the metals is accomplished by an electric arc.

OXYFUEL GAS WELDING

Oxy fuel gas welding (OFW) is the term used to describe the group of fusion welding operations that burn various fuels mixed with oxygen to perform welding. Oxy fuel gas is also commonly used in cutting torches to cut and separate metal plates and other parts. The most important OFW process is **oxyacetylene welding**.

Oxyacetylene welding:

Oxyacetylene welding (OAW) is a fusion-welding process performed by a high-temperature flame from combustion of acetylene and oxygen. The flame is directed by a welding torch. A filler metal is sometimes added, and pressure is occasionally applied in OAW between the contacting part surfaces. Atypical OAW operation is sketched in Fig 6.

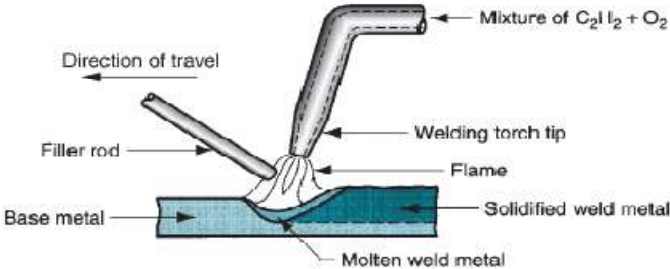

Fig 6: Oxyacetylene Gas welding

Working: The gas cylinder and oxygen cylinder connected to the welding torch through pressure regulators. Now the regulate pressure of gas and oxygen supplied to the torch where they properly mixed. The flame is ignited by a striker. Take care the tip of torch is pointing downward.

Now the flame is controlled through valves situated in welding torch. The flame is set at natural flame or carburizing flame or oxidizing flame according to the welding condition. Now the welding torch moved along the line where joint to be created. This will melt the interface part and join them permanently.

Principle reactions:

Acetylene (C₂H₂) is the most popular fuel among the OFW group because it is capable of higher temperatures than any of the others up to 3480⁰C. The flame in OAW is produced by the chemical reaction of acetylene and oxygen in two stages. The first stage is defined by the reaction



the products of which are both combustible, which leads to the second-stage reaction.

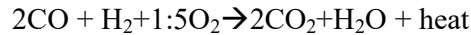

The heat liberated because of the above chemical reaction is enough to melt the base metal and to add the filler metal to accomplish the required weld joint.

OAW equipment: -The following Fig 7 shows the details about OAW equipment.

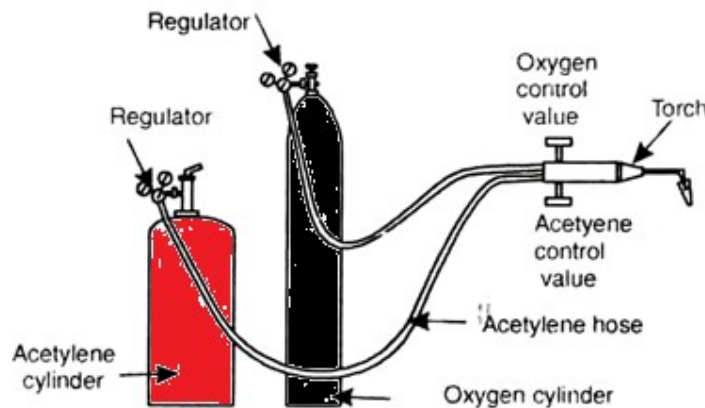

Fig 7: OAW equipment

Welding Torch:

Welding torches are most important part of gas welding. Both the fuel gas and oxygen at suitable pressure fed through hoses to the welding torch. There are valves for each gas which control the flow of gases inside the torch. Both gases mixed there and form a flammable mixture. These gases ignite to burn at the nozzle. The fire flame flow through nozzle and strikes at welding plates. The nozzle thickness depends on the size of the welding plates and material to be welded.

Oxygen Cylinder:

For proper burning of fuel, appropriate amount of oxygen required. This oxygen supplied by a oxygen cylinder. A black line is used to indicate oxygen cylinder.

Fuel Gas Cylinder:

Gas cylinder is filled either by oxy acetylene gas, hydrogen gas, natural gas or other flammable gas. The fuel gas selection is depends on the welding material. Mostly oxy

acetylene gas is used for all general purpose of welding. Normally these cylinders have Maroon line to indicate it. The fuel gases passes through it.

Pressure regulator:

Both oxygen and fuel gases are filled in cylinder at high pressure. These gases cannot use at this high pressure for welding work, so a pressure regulator is used between flow. It supplies oxygen at pressure about 70 – 130 KN / M2 and gas at 7 – 103 KN / M2 to the welding torch.

Types of Flame (or Oxy acetylene Flame settings):

1. Neutral Flame
2. Carburizing Flame
3. Oxidizing Flame

1. Neutral Flame: The neutral flame as shown in above figure is produced when the ratio of oxygen to acetylene, in the mixture leaving the torch, is almost exactly one-to-one. It's termed “neutral” because it will usually have no chemical effect on the metal being welded. It will not oxidize the weld metal; it will not cause an increase in the carbon content of the weld metal. As shown in Fig 8.

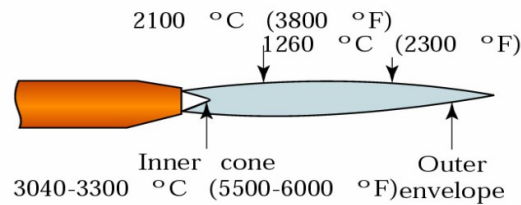

Fig 8: Neutral Flame

The neutral flame is commonly used for the welding of: Mild Steel, Stainless steel, Cast iron, Copper, Aluminium.

2. Carburizing (or Reducing) Flame: The Carburizing (or Reducing) Flame, is created when the proportion of acetylene in the mixture is higher than that required to produce the neutral flame. A Carburizing flame has an approximate temperature of 3038°C.

A reducing flame can be recognized by acetylene feather which exists between the inner cone and the outer envelope. The outer flame envelope is longer than that of the neutral flame and is usually much brighter in colour. As shown in Fig 9.

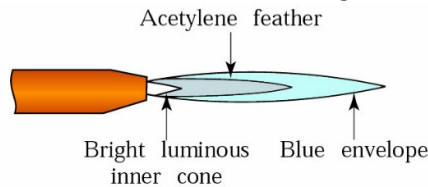

Fig9: Carburizing Flame

Use of Carburizing Flame:With iron and steel, it produces very hard, brittle substance known as **iron carbide**. This chemical change makes the **metal unfit** for many applications in which the weld may need to be **bent or stretched**.

Note:Metals that tend to absorb carbon should not be welded with reducing flame.

3. Oxidizing Flame: The oxidizing flame results from burning a mixture which contains more oxygen than required for a neutral flame. It will oxidize or "burn" some of the metal being welded.

The outer flame envelope is much shorter and tends to fan out at the end on the other hand the neutral and carburizing envelopes tend to come to a sharp point.

An oxidizing flame tends to be hotter than the neutral flame. This is because of excess oxygen and which causes the temperature to rise as high as 3500°C as shown in Fig 10.

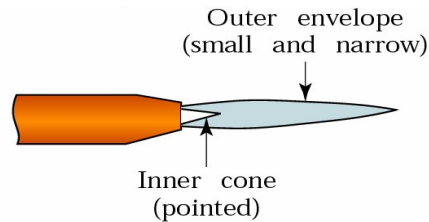

Fig 10: Oxidizing Flame

The Oxidizing Flame is commonly used for the welding of:

- (i) Copper base metals
 - (ii) Zinc base metals
 - (iii) A few types of ferrous metals, such as manganese steel and cast iron.
- The Composition of filler rod is usually same as that of base metal. The filler metal is used to fill up the cavity made during edge preparation. A flux material is also used during welding to remove impurities and oxides present on the metal surfaces to be joined.

Application:

- It is used to join thin metal plates.
- It can be used to join both ferrous and non-ferrous metals.
- Gas welding is mostly used in fabrication of sheet metal.
- It is widely used in [automobile](#) industries.

Advantages:

- It is easy to operate, and does not require a high skill operator.
- Equipment cost is low compared to other welding processes like MIG, TIG etc.
- It can be used at site.
- Equipment's are more portable than other types of welding.
- It can also be used as gas cutting.

Disadvantages:

- It provides a low surface finish. This process needs a finishing operation after welding.
- Gas welding has a large heat affected zone which can cause a change in mechanical properties of the parent material.
- Higher safety issues due to the naked flame of high temperature.
- It is suitable only for soft and thin sheets.

- Slow metal joining rate.
- No shielding area which causes more welding defects.

ARC WELDING

Arc welding (AW) is a fusion-welding process in which coalescence of the metals is achieved by the heat of an electric arc between an electrode and the work.

Working principle:

- An electric arc is a discharge of electric current across a gap in a circuit. It is sustained by the presence of a thermally ionized column of gas (called a plasma) through which current flows.
- To initiate the arc in an AW process, the electrode is brought into contact with the work and then quickly separated from it by a short distance. The electric energy from the arc thus formed produces temperatures of 5500_C (10,000_F) or higher, sufficiently hot to melt any metal.
- A pool of molten metal, consisting of base metal(s) and filler metal (if one is used) is formed near the tip of the electrode. In most arcwelding processes, filler metal is added during the operation to increase the volume and strength of the weld joint.

Arc Welding equipment: - Arc welding equipment set up is as shown in Fig 11.

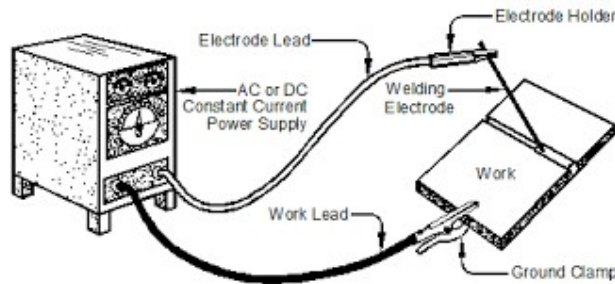

Fig 11: Arc welding equipment setup

Welding Power Sources - Shielded metal arc welding may utilize either alternating current (AC) or direct current (DC), but in either case, the power source selected must be of the constant current type. This type of power source will deliver a relatively constant amperage or welding current regardless of arc length variations by the operator. The amperage determines the amount of heat at the arc and since it will remain relatively constant, the weld beads produced will be uniform in size and shape. Whether to use an AC, DC, or AC/DC power source depends on the type of welding to be done and the electrodes used.

Welding Cables - The electrode cable and the ground cable are important parts of the welding circuit. They must be very flexible and have a tough heat-resistant insulation. Connections at the electrode holder, the ground clamp, and at the power source lugs must be soldered or well crimped to assure low electrical resistance. The cross-sectional area of the cable must be sufficient size to carry the welding current with a minimum of voltage drop. Increasing the cable length necessitates increasing the cable diameter to lessen resistance and voltage drop.

Electrode Holder - The electrode holder connects to the welding cable and conducts the welding current to the electrode. The insulated handle is used to guide the electrode over the weld joint and feed the electrode into the weld

puddle as it is consumed. Electrode holders are available in different sizes and are rated on their current carrying capacity.

Ground Clamp - The ground clamp is used to connect the ground cable to the work piece. It may be connected directly to the work or to the table or fixture upon which the work is positioned. Being a part of the welding circuit, the ground clamp must be capable of carrying the welding current without overheating due to electrical resistance.

Electrode: An electrode is a tool used in arc welding to produce electric arc. It may be used as a positively charged anode or as a negatively charged cathode.

Types of Arc Welding Electrodes: Based on their characteristics, arc welding electrodes can be broadly classified into two types. They are:

- Consumable electrode
- Non-consumable Electrode

Consumable Electrode:

- If the melting point of an arc welding electrode is less, it melts and fills the gap in the workpiece. Such an electrode is called consumable electrode.
- In arc welding, to produce deep weld, consumable electrode is connected to the positive terminal of the power supply (i.e., it is made as anode) while workpiece is connected to the negative terminal of the power supply (i.e., it is made cathode).
- This is because, heat concentration is always higher in the anode than in cathode. When consumable electrode is made as anode, it melts faster and easily fills the gap in the workpiece.
- Consumable electrodes are usually coated with a flux material. This is done to protect the arc and the weld from the external atmosphere.
- Metal inert gas welding is an arc welding technique that uses a consumable electrode.

Non-consumable electrode:

- If the melting point of the arc welding electrode is high, it does not melt to fill the gap in the workpiece. Such an electrode is called non-consumable electrode.
- If a non-consumable electrode is used, either the workpiece should have a low melting point or filler metal with low melting point should be used, to fill the gap in the workpiece.
- As non-consumable electrodes do not melt, heat concentration should be high in the workpiece. Hence, in non-consumable electrode processes, to produce deep weld, the electrode is made cathode and workpiece is made anode.
- Tungsten is a non-consumable electrode whose melting point is 3422 °C. It is used in tungsten inert gas welding.

Arc Blow –

Arc blow occurs during the welding of magnetic materials with DC.

- The effect of arc blow is maximum when welding corners where magnetic field concentration is maximum.
- The effect is particularly noticeable when welding with bare electrodes or when using currents below or above

- Again, the problem of arc blow gets magnified when welding highly magnetic materials such as Ni alloys, because of the strong magnetic fields set up by these metals.
- Cause: Unbalanced magnetic forces.

Arc blow because of magnetic field is as shown in Fig 12.

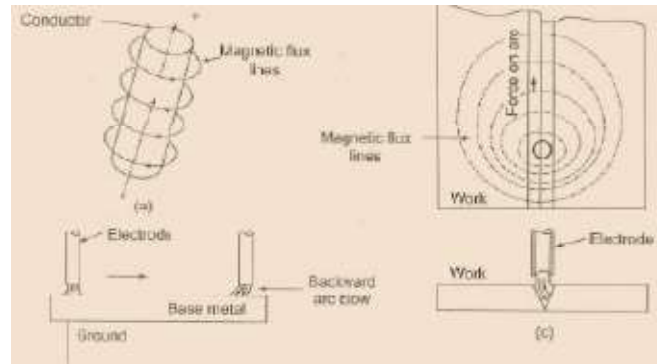

Fig 12: Arc Blow

Voltage – Current characteristic: - (Numerical problems mostly appear from this topic)

1. For given V---- Operating voltage or Welding voltage
I ---- Operating current or Welding current
OCV---- Open circuit voltage
SCC ---- Short circuit current

$$\left(\frac{V}{OCV}\right) + \left(\frac{I}{SCC}\right) = 1$$

2. Duty cycle: -The percentage of time that a welding machine can be used at its rated output without overloading.

$$\text{Required duty cycle, } T = \left(\frac{I}{I_{MAX}}\right)^2 t$$

Where, t = rated duty cycle

I = rated current at the rated duty cycle

I MAX= Maximum current at the rated duty cycle

3. The arc voltage depends only upon the arc length

$$V = k_1 + k_2 l, \text{ Volts}$$

Where l is the arc length in mm and k₁ and k₂ are constants,

k₁ = 10 to 12; and k₂ = 2 to 3

4. The minimum Arc voltage is given by

$$V_{min} = (20 + 0.04 l) \text{ Volts}$$

5. Power Requirements - watt was the unit of electrical power and can be calculated by the formula: Watts = Volts × Amperes

6. Metal Deposition Rate: - Area x velocity

7. Heat input required for Arc welding, $Q = (V \cdot I \cdot 60) / (S \cdot 1000)$

Where , $Q =$ Heat input KJ/mm

Shielded metal arc welding (SMAW):

- ❖ Shielded Metal Arc Welding Shielded metal arc welding (SMAW) is an AW process that uses a consumable electrode consisting of a filler metal rod coated with chemicals that provide flux and shielding.
- ❖ The process is illustrated in Figures. SMAW is sometimes called stick welding) is typically 225 to 450 mm (9–18 in) long and 2.5 to 9.5mm (3/32–3/8 in) in diameter.
- ❖ The filler metal used in the rod must be compatible with the metal to be welded, the composition usually being very close to that of the base metal.
- ❖ The coating consists of powdered cellulose (i.e., cotton and wood powders) mixed with oxides, carbonates, and other ingredients, held together by a silicate binder. Metal powders are also sometimes included in the coating to increase the amount of filler metal and to add alloying elements.
- ❖ The heat of the welding process melts the coating to provide a protective atmosphere and slag for the welding operation. It also helps to stabilize the arc and regulate the rate at which the electrode melts.
- ❖ During operation the bare metal end of the welding stick (opposite the welding tip) is clamped in an electrode holder that is connected to the power source. The holder has an insulated handle so that it can be held and manipulated by a human welder.
- ❖ Currents typically used in SMAW range between 30 and 300 A at voltages from 15 to 45 V.
- ❖ Shielded metal arc welding is usually performed manually. Common applications include construction, pipelines, machinery structures, shipbuilding, job shop fabrication, and repair work. It is preferred over oxyfuel welding for thicker sections—above 5 mm
- ❖ Base metals include steels, stainless steels, cast irons, and certain nonferrous alloys.
- ❖ It is not used or seldom used for aluminum and its alloys, copper alloys, and titanium.

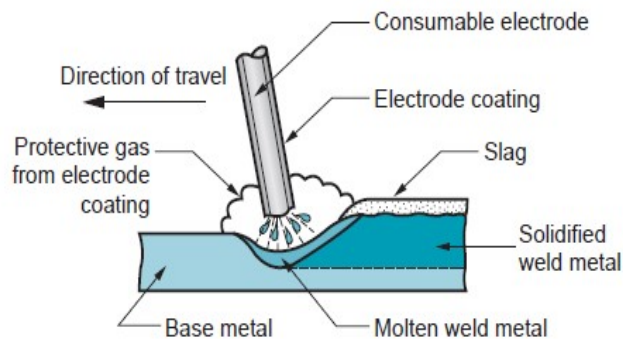

- ❖ A disadvantage of shielded metal arc welding as a production operation is the use of the consumable electrode stick. As the sticks are used up, they must periodically be changed. This reduces the arc time with this welding process.
- ❖ Another limitation is the current level that can be used. Because the electrode length varies during the operation and this length affects the resistance heating of the electrode, current levels must be maintained within a safe range or the coating will overheat and melt prematurely when starting a new welding stick.

Submerged Arc Welding (SAW)

- ❖ Submerged arc welding (SAW) is an arc-welding process that uses a continuous, consumable bare wire electrode, and arc shielding is provided by a cover of granular flux.
- ❖ The electrode wire is fed automatically from a coil into the arc. The flux is introduced into the joint slightly ahead of the weld arc by gravity from a hopper, as shown in Figure.

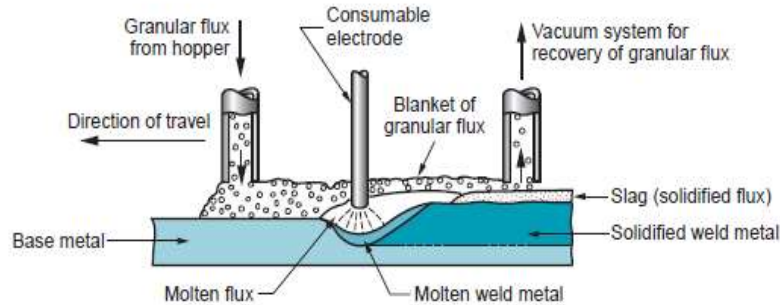

- ❖ The blanket of granular flux completely submerges the welding operation, preventing sparks, spatter, and radiation that are so hazardous in other AW processes.
- ❖ The portion of the flux closest to the arc is melted, mixing with the molten weld metal to remove impurities and then solidifying on top of the weld joint to form a glass like slag.
- ❖ Submerged arc welding is widely used in steel fabrication for structural shapes (e.g., welded I-beams); longitudinal and circumferential seams for large diameter pipes, tanks and pressure vessels; and welded components for heavy machinery.
- ❖ Low-carbon, low-alloy, and stainless steels can be readily welded by SAW; but not high-carbon steels, tool steels, and most nonferrous metals. Because of the gravity feed of the granular flux, the parts must always be in a horizontal orientation, and a
- ❖ Backup plate is often required beneath the joint during the welding operation.

Gas Tungsten Arc Welding (GTAW)

- ❖ It is an AW process that uses a non consumable tungsten electrode and an inert gas for arc shielding.
- ❖ The term TIG welding (tungsten inert gas welding) is often applied to this process. GTAW can be implemented with or without a filler metal.
- ❖ When a filler metal is used, it is added to the weld pool from a separate rod or wire, being melted by the heat of the arc rather than transferred across the arc as in the consumable electrode AW processes.
- ❖ Tungsten is a good electrode material due to its high melting point of 3410°C
- ❖ Typical shielding gases include argon, helium, or a mixture of these gas elements.
- ❖ GTAW is applicable to nearly all metals in a wide range of stock thicknesses. It can also be used for joining various combinations of dissimilar metals. Its most common applications are for aluminum and stainless steel.
- ❖ Cast irons, wrought irons, and of course tungsten are difficult to weld by GTAW.
- ❖ Advantages of GTAW in the applications to which it is suited include high-quality welds, no weld spatter because no filler metal is transferred across the arc, and little or no post weld cleaning because no flux is used.
- ❖ GTAW is as shown in figure.

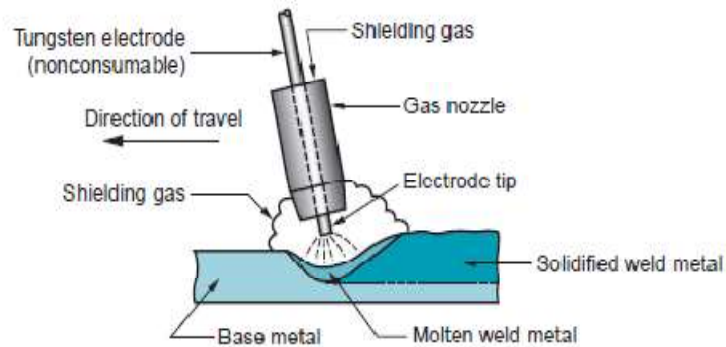

Plasma Arc Welding

- ❖ Plasma arc welding (PAW) is a special form of gas tungsten arc welding in which a constricted plasma arc is directed at the weld area.
- ❖ In PAW, a tungsten electrode is contained in a specially designed nozzle that focuses a high-velocity stream of inert gas (e.g., argon or argon–hydrogen mixtures) into the region of the arc to form a high velocity, intensely hot plasma arc stream. PAW is as shown in figure.

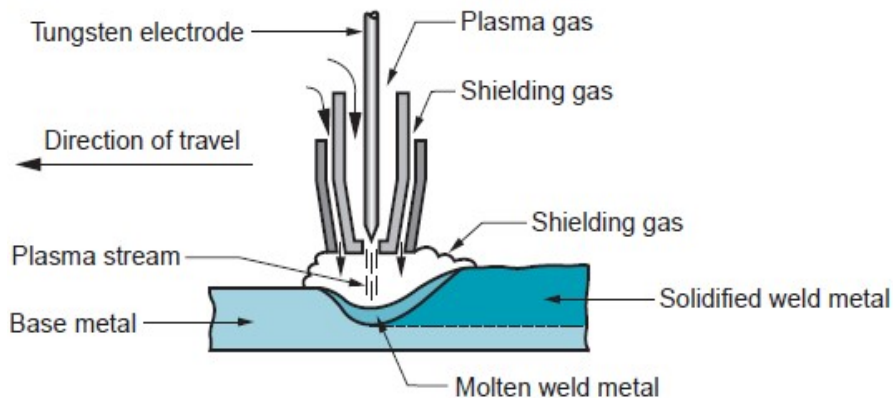

- ❖ Argon, argon–hydrogen, and helium are also used as the arc-shielding gases.
- ❖ Temperatures in plasma arc welding reach $17,000^{\circ}\text{C}$ or greater, hot enough to melt any known metal. The reason why temperatures are so high in PAW derives from the constriction of the arc. The power is highly concentrated to produce a plasma jet of small diameter and very high power density.
- ❖ PAW, its advantages in these applications include good arc stability, better penetration control than most other AW processes, high travel speeds, and excellent weld quality.
- ❖ The process can be used to weld almost any metal, including tungsten. Difficult-to-weld metals with PAW include bronze, cast irons, lead, and magnesium. Other limitations include high equipment cost and larger torch size than other AW operations, which tends to restrict access in some joint configurations.

Plasma arc welding is of two types:

- ❖ Non-transferred plasma arc welding process and transferred arc welding process.
- ❖ In the former, the arc is established between the electrode and the nozzle and in the latter process the arc is established between the electrode and the workpiece.
- ❖ The differences between these two processes are presented as follows.

Transferred plasma arc welding process	Non-transferred plasma arc welding process
Arc is established between electrode and workpiece	Arc is established between electrode and nozzle.
The work piece is part of the electrical circuit and heat is obtained from the anode spot and the plasma jet. Therefore, higher amount of energy is transferred to work. This is useful for welding.	The work piece is not part of the electrical circuit and heat is obtained from the plasma jet. Therefore, less energy is transferred to work. This is useful in cutting.
Higher penetration is obtained, so thicker sheets can be welded.	Less penetration is obtained, so thin sheets can be welded.
Higher process efficiency.	Less process efficiency.

- ❖ The schematic representation of both is as shown in figure.

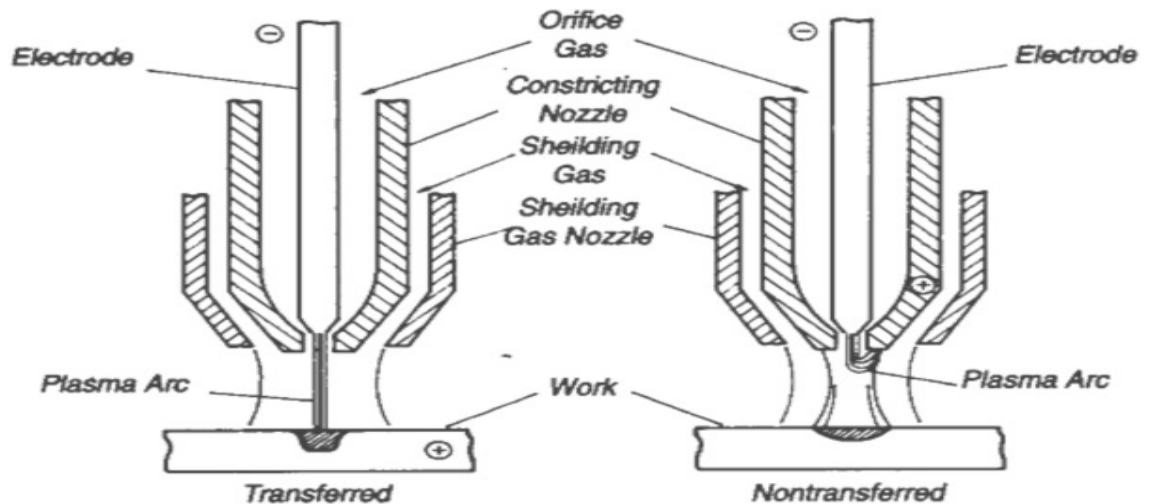

Thermit Welding:

- ❖ Thermit welding is the joining process in which heat required for melting and joining of components is obtained due to the exothermic chemical reaction.
- ❖ When the initiation of igniting powder is given by using the matchbox, the heat generated due to the burning of igniting powder and it is used for initiating the chemical reaction taking place in the thermit mixture is used for melting and joining of plates called as thermit welding.
- ❖ The chemical reaction in thermit welding is:

$$8 \text{ Al} + 3\text{Fe}_3 \text{ O}_4 \rightarrow 9\text{Fe} + 4 \text{ Al}_2 \text{ O}_3 + \text{Heat}$$
- ❖ Al + Fe₃ O₄ is called thermit mixture, and due to the exothermic chemical reaction, three products are produced, they are iron (used as filler material), aluminum oxide (as slag) and heat for melting.
- ❖ Thermit mixture (8Al + 3Fe₃O₄) can be ignited only at about 1200°C but special igniting powders are used to initiate the reaction at much lower temperature Barium.
- ❖ Peroxide (Ba₂O₂) or 'Ba₂O₂ + Al' or powdered manganese are used as special igniting powders. A thin layer of this igniting powder, thereby initiating the reaction shown above

which releases a tremendous amount of heat producing a temperature of about 3000°C which will change the iron into a liquid state.

- ❖ Thermit welding is developed for joining of railway track rails in the remote areas like hill areas and forest areas. Also, thermit welding is used for repair of heavy parts such as tracks, spokes of driving wheels, broken motor castings, connecting rods, especially in the welding of pipes.

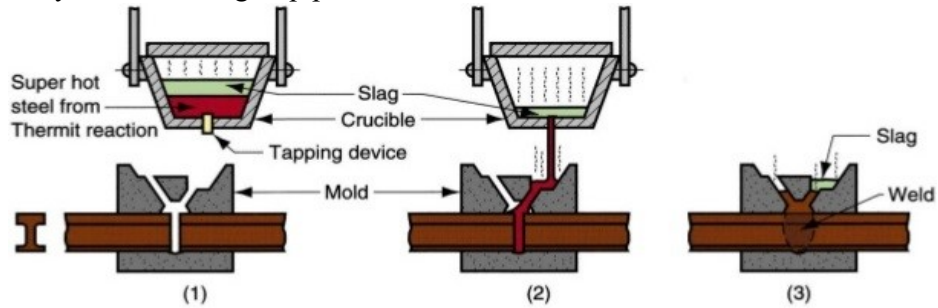

Thermit welding: (1) Thermit ignited; (2) crucible tapped, superheated metal flows into mold; (3) metal solidifies to produce weld joint.

MANUFACTURING PROCESSES

UNIT-IV

Pressure Welding: Pressure welding is a process in which external pressure is applied to produce welded joints either at temperatures below the melting point, which is solid state welding, or at a temperature above the melting point, which is fusion state welding.

Resistance Welding

Resistance welding Resistance welding is a group of welding process in which coalescence is produced by the heat obtained from the resistance of the work to the flow of electric current in a circuit of which the work is a part and by the application of pressure. No filler metal is needed in this process.

Resistance Welding Resistant welding is also one of the fusion welding techniques that utilize heat and pressure to make the welded joint. Required heat is generated at the junction due to flowing current through it and resistance offered.

The amount of heat generated is $H = I^2 Rt$ ----- (i)

Where H is the heat generated, I is the current flowing, R resistance of junction, t is the time for which current flows.

Principle of Resistance Welding: Principle of resistance welding can be explained with the help of diagram shown in Figure. It consists of workpieces to be welded, two opposing electrodes a mechanism to apply pressure to squeeze the workpieces, AC power supply to maintain the current, a circuit breaker with times to stop the flowing current after a preset time.

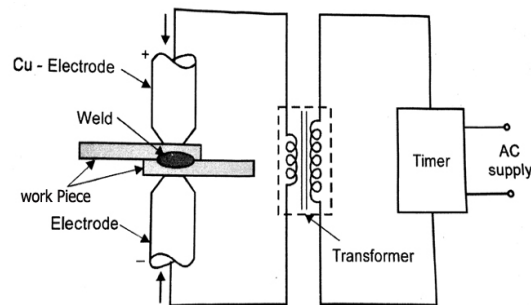

Types of Resistance Welding: Depending upon the joint to be make resistance welding can be divided into different categories:

- (a) Spot welding,
- (b) Seam welding,
- (c) Projection welding, these welding techniques are explained below.

Spot Welding:

- In this welding fusion of the faying surfaces of a lap joint is achieved at one location by opposing electrodes. Thickness of workpiece should be up to 3 mm.
- The joint made so is not air tight or waterproof. Size and shape of spot weld depends upon the size and shape of electrode tips.
- Shape can be circular, hexagonal, square or any other. Strength of a spot weld is equal to the strength of metal of workpiece.
- It is widely used in mass production of automobiles, appliances, metal furniture and other products made of sheet metal. There are approximately 10,000 individual spot welds in a single car body.

➤ **Steps in spot welding:**

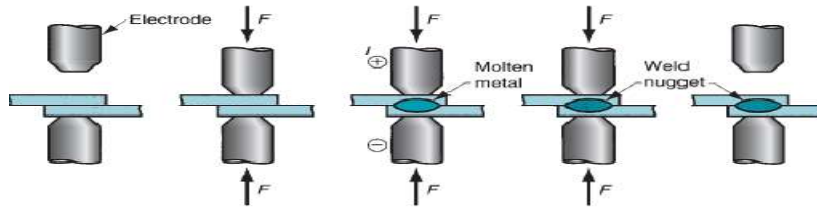

- (1) Parts inserted between open electrodes,
 - (2) Electrodes close and force is applied,
 - (3) Weld time— current is switched on,
 - (4) Current is turned off but force is maintained or increased (a reduced current is sometimes applied near the end of this step for stress relief in the weld region)
 - (5) Electrodes are opened, and the welded assembly is removed.
- Resistance Spot Welding Machine is as shown in figure: (A rocker Arm Type)

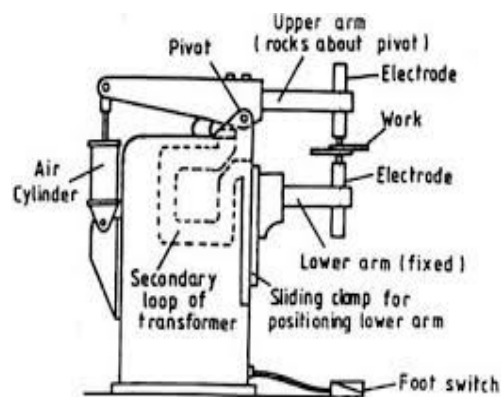

Resistance Seam Welding:

- In this case rotating wheels are used as welding electrodes. It is like making a continuous series of spot welds along the lap joint. This process produces air tight and leak proof joint.
- The lap joint to be made is allowed to pass through between rotating electrodes. These electrodes press the workpiece and fuse it to make a continuous lap joint.
- This welding is used in production of gasoline tanks, automobile, welding procedure is shown in Figure.

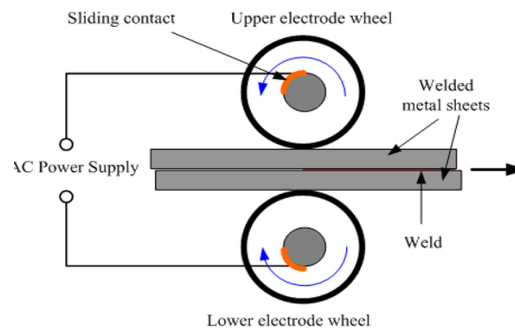

Projection Welding:

- In **resistance projection welding (RPW)**, small projections are formed on one or both pieces of the base metal to obtain contact at a point which localize the current flow and concentrate the heat.
- Under pressure, the heated and softened projections collapse and a weld is formed.
- Projection on the upper component is pressed against the lower component by electrode force. The projection collapses and a fused weld nugget are formed with the application of current.

- This technique is of special value in mounting attachments to surfaces of which the back side is inaccessible to a welding operator. Projection welding as shown in figure.

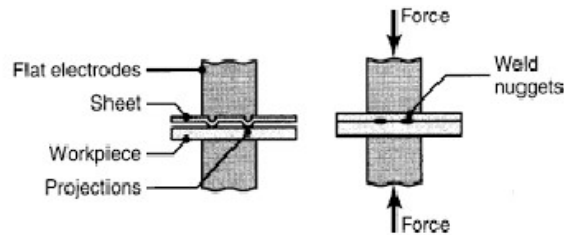

Heat and Power requirements in Resistance Welding: (Numerical Problems)

1. Heat Required: $H = I^2 R t$ ----- (i)
2. Power: $P = V \times I$ ----- (ii)

Where, V= Voltage, I = Current

Example 1: Spot welding of two 1 mm thick sheets of steel (Density = 8000 Kg/m³) is carried out successfully by passing a certain amount of current for 0.1 sec, through the electrodes. The resultant weld nugget formed is 5 mm in diameter & 1.5 mm thick. If the latent heat of fusion of steel is 1400 KJ/Kg and the effective resistance in welding operation is 200 micro ohms. Calculate the current passing through electrode.

Example 2: A resistance spot-welding operation is performed on two pieces of 1.5-mm-thick sheet steel using 12,000 A for a 0.20 s duration. The electrodes are 6 mm in diameter at the contacting surfaces. Resistance is assumed to be 0.0001 V, and the resulting weld nugget is 6 mm in diameter and 2.5 mm thick. The unit melting energy for the metal $U_m = 12.0 \text{ J/mm}^3$. What portion of the heat generated was used to form the weld nugget, and what portion was dissipated into the work metal, electrodes, and surrounding air?

Example 3: Aluminum strips of 2 mm thickness are to be joined together by resistance spot welding by applying an electric current of 6000 A and 0.15 Sec. The heat required for melting Al is 2.9 J/mm^3 . The diameter and thickness of weld nugget are 5 mm & 2.5 mm, resistance $75 \mu\Omega$. Determine the % of total energy utilized in welding process.

Solid State Welding

Solid State Welding is a welding process, in which two work pieces are joined under a pressure providing an intimate contact between them and at a temperature essentially below the melting point of the parent material. Bonding of the materials is a result of diffusion of their interface atoms. The following processes are related to Solid State welding:

- (i) Friction Welding (FRW)
- (ii) Induction Welding
- (iii) Explosive Welding (EXW)

Friction Welding:

- Friction welding (FRW) is a solid state welding process in which coalescence is achieved by frictional heat combined with pressure.
- The friction is induced by mechanical rubbing between the two surfaces, usually by rotation of one part relative to the other, to raise the temperature at the joint interface to the hot working range for the metals involved.
- Then the parts are driven toward each other with sufficient force to form a metallurgical bond.

- The sequence of operation is as shown in figure for welding two cylindrical parts, the typical application. The axial compression force upsets the parts, and a flash is produced by the material displaced. Any surface films that may have been on the contacting surfaces are expunged during the process. The flash must be subsequently trimmed (e.g., by turning) to provide a smooth surface in the weld region. When properly carried out, no melting occurs at the faying surfaces. No filler metal, flux, or shielding gases are normally used.

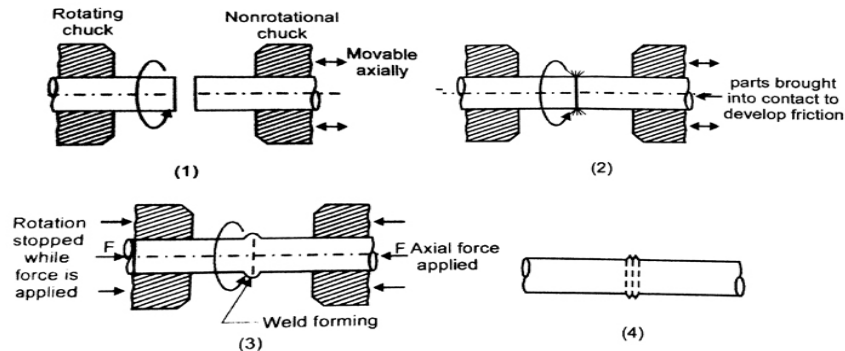

- One of the most important types of friction welding is friction stir welding in which, a non-consumable rotating tool is used to applied friction of welding plates. The schematic representation of it as shown in figure:

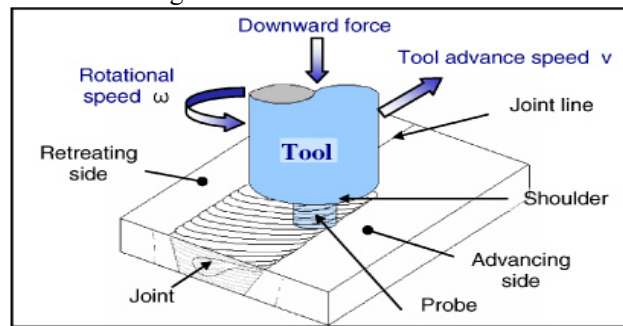

Explosive Welding (EXW):

- Explosive Welding is a Solid State Welding process, in which welded parts (plates) are metallurgical bonded as a result of oblique impact pressure exerted on them by a controlled detonation of an explosive charge.
- One of the welded parts (base plate) is rested on an anvil; the second part (flyer plate) is located above the base plate with an angled or constant interface clearance. Explosive charge is placed on the flyer plate. Detonation starts at an edge of the plate and propagates at high velocity along the plate. The maximum detonation velocity is about 120% of the material sonic velocity. The slags (oxides, nitrides and other contaminants) are expelled by the jet created just ahead of the bonding front.
- The schematic representation of explosive welding is as shown in figure:

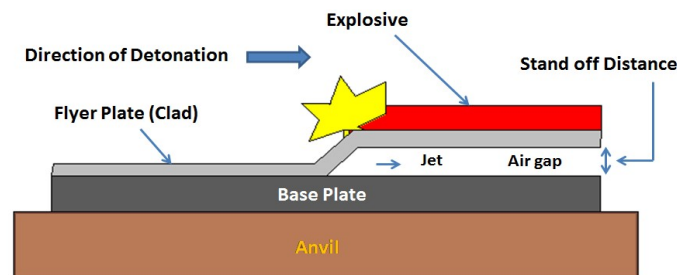

- Most of the commercial metals and alloys may be bonded (welded) by Explosive Welding. Dissimilar metals may be joined by Explosive Welding: Copper to steel, Nickel to steel, Aluminum to steel, Tungsten to steel, Titanium to steel, Copper to aluminum.

Induction Welding:

- Induction welding is a form of welding that uses electromagnetic induction to heat the workpiece. The welding apparatus contains an induction coil that is energised with a radio-frequency electric current.
- This generates a high-frequency electromagnetic field that acts on either an electrically conductive or a ferromagnetic workpiece. In an electrically conductive workpiece, the main heating effect is resistive heating, which is due to induced currents called eddy currents.
- In a ferromagnetic workpiece, the heating is caused mainly by hysteresis, as the electromagnetic field repeatedly distorts the magnetic domains of the ferromagnetic material. In practice, most materials undergo a combination of these two effects.
- Nonmagnetic materials and electrical insulators such as plastics can be induction-welded by implanting them with metallic or ferromagnetic compounds, called susceptors, that absorb the electromagnetic energy from the induction coil, become hot, and lose their heat to the surrounding material by thermal conduction. Plastic can also be induction welded by embedding the plastic with electrically conductive fibers like metals or carbon fiber. Induced eddy currents resistively heat the embedded fibers which lose their heat to the surrounding plastic by conduction. Induction welding of carbon fiber reinforced plastics is commonly used in the aerospace industry.

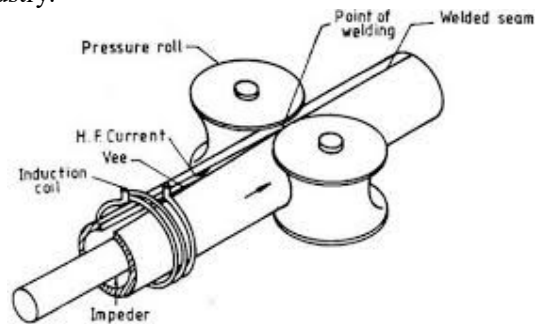

Welding Defects & Remedies

Welding Defects can be defined as the irregularities formed in the given weld metal due to wrong welding process or incorrect welding patterns, etc. The defect may differ from the desired weld bead shape, size, and intended quality. Welding defects may occur either outside or inside the weld metal. Welding defects can be classified into two types as external and internal defects:

External Welding Defects:

1. Weld Crack
2. Undercut
3. Spatter
4. Porosity
5. Overlap
6. Crater

Internal Welding Defects:

1. Slag Inclusion
2. Incomplete Fusion
3. Necklace cracking
4. Incompletely filled groove or Incomplete penetration

Weld Crack: This is the most unwanted defect of all the other welding defects. Welding cracks can be present at the surface, inside of the weld material or at the heat affected zones. Cracks welding defect Crack can also appear at different temperatures:

Hot Crack – It is more prominent during crystallization of weld joints where the temperature can rise more than 10,000-degree Celsius.

Cold Crack – This type of crack occurs at the end of the welding process where the temperature is quite low. Sometimes cold crack is visible several hours after welding or even after few days.

➤ **Causes of Weld Crack:**

1. Poor ductility of the given base metal.
2. The presence of residual stress can cause a crack on the weld metal.
3. The rigidity of the joint which makes it difficult to expand or contract the metals.
4. If there is high content on sulphur and carbon then also the cracks may appear.
5. Using hydrogen as a shielding gas while welding ferrous materials.

➤ **Remedies for Weld crack:**

1. Using appropriate materials may decrease the chances of crack.
2. Preheating the weld and reducing the cooling speed joint helps in reducing crack.
3. Reduce the gap between the weld joints by using reasonable weld joints.

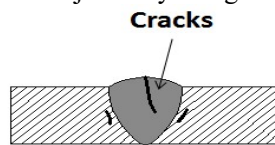

Undercut welding defects: When the base of metal melts away from the weld zone, then a groove is formed in the shape of a notch, then this type of defect is known as Undercut. It reduces the fatigue strength of the joint.

➤ **Causes of Undercut:**

1. If the arc voltage is very high then this defect may occur.
2. If we use the wrong electrode or if the angle of the electrode is wrong, then also the defect may form.
3. Using a large electrode is also not advisable.
4. High electrode speed is also one of the reasons for this defect.

➤ **Remedies for Undercut:**

1. Reduce the arc length or lower the arc voltage.
2. Keep the electrode angle from 30 to 45 degree with the standing leg.
3. The diameter of the electrode should be small.
4. Reduce the travel speed of the electrode.

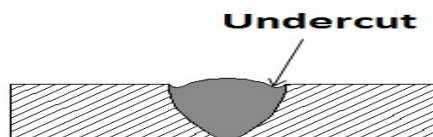

Spatter welding defect: When some metal drops are expelled from the weld and remain stuck to the surface, then this defect is known as Spatter.

➤ **Causes Of Spatter:**

1. High Welding current can cause this defect.
2. The longer the arc the more chances of getting this defect.
3. Incorrect polarity.
4. Improper gas shielded may also cause this defect.

➤ **Remedies for Spatter:**

1. Reducing the arc length and welding current
2. Using the right polarity and according to the conditions of the welding.
3. Increasing the plate angle and using proper gas shielding.

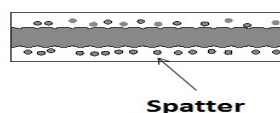

Porosity welding defect: Porosity in the condition in which the gas or small bubbles gets trapped in the welded zone.

➤ **Causes of Porosity:**

1. It occurs when the electrode is not coated properly.
2. Using a longer arc may also increase its chances.
3. Increased welding currents.
4. Rust or oil on the welding surface.

➤ **Remedies for porosity:**

1. Proper selection of the electrode.
2. Decreasing the welding current.
3. Using smaller arc and slowing the process to allow the gases to escape.
4. Remove rust or oil from the surface and use a proper technique.

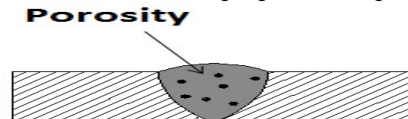

Overlap welding defects: When the weld face extends beyond the weld toe, then this defect occurs. In this condition the weld metal rolls and forms an angle less than 90 degrees.

➤ **Causes of Overlap:**

1. Improper welding technique.
2. By using large electrodes this defect may occur.
3. High welding current

➤ **Remedies for Overlap:**

1. Using a proper technique for welding.
2. Use small electrode.
3. Less welding current.

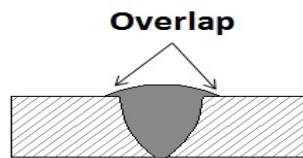

The various types of internal welding defects with their causes and remedies are listed below:

Slag inclusion welding defects: If there is any slag in the weld, then it affects the toughness and metal weldability of the given material. This decreases the structural performance of the weld material. Slag is formed on the surface of the weld or between the welding turns.

➤ **Causes Of Slag:**

1. Slag is formed if the welding current density is very small, as it does not provide the required amount of heat for melting the metal surface.
2. If the welding speed is too fast then also slag may occur.
3. If the edge of the weld surface is not cleaned properly then also slag may form.
4. Improper welding angle and travel rate of welding rod.

➤ **Remedies for Slag Inclusion:**

1. Increase the current density
2. Adjust the welding speed so that the slag and weld pool do not mix with each other.
3. Clean the weld edges and remove the slags of previous weld layers
4. Have a proper electrode angle and travel rate.

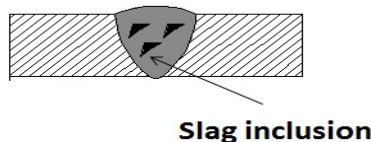

Incomplete fusion welding defects: Incomplete fusion occurs when the welder does not accurately weld the material and the metal pre solidifies which leads to a gap which is not filled with the molten metal.

➤ **Causes of Incomplete fusion:**

1. It occurs because of the low heat input.
2. When the weld pool is very large and runs ahead of the arc.
3. When the angle of the joint is too low.
4. Incorrect electrode and torch angle may also lead to incomplete fusion.
5. Unproper bead position.

➤ **Remedies for Incomplete Fusion:**

1. Increasing the welding current and decreasing the travel speed helps in removing the chances of incomplete fusion.
2. Reducing the deposition rate.
3. Increasing the joint angle.
4. Try to position the electrode and torch angle properly so that the edges of the plate melt away.
5. Positioning the bead properly so that the sharp edges with other beads can be avoided.

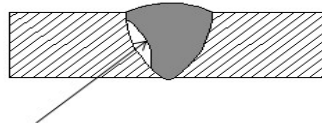

Incomplete Fusion

Necklace Cracking: It occurs in the use of electron beam welding where the weld does not penetrate properly. Therefore, the molten metal does not flow into the cavity and results in a cracking known as “Necklace Cracking”.

➤ **Causes of Necklace Cracking:**

1. Improper welding technique.
2. It occurs in materials such as nickel base alloys, stainless steel, carbon steels and Tin alloys.
3. Using high speed of electron beam welding

➤ **Remedies for Necklace Cracking:**

1. Using a proper welding technique reduce the chances of necklace cracking.
2. Using proper materials for welding.
3. Using a constant speed during the welding process.
3. Improper welding technique

Incompletely Filled Groove or Incomplete Penetration Incomplete Penetration welding defect

These defects occur only in the butt welds where the groove of the metal is not filled completely. It is also called as incomplete penetration defect.

➤ **Causes of an Incomplete filled groove are:**

1. Less deposition of the weld metal
2. Use of improper size of the electrode
3. Improper welding technique

➤ **Remedies for Incomplete filled groove are:**

1. More deposition of the weld metal.
2. Use a proper size of the electrode.
3. By using a proper welding technique.

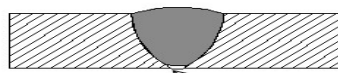

Incomplete Penetration

Manufacturing Processes

UNIT-V

Metal Forming Processes: Forming is the process of obtaining the required shape and size on the raw material by subjecting *the material to plastic deformation through the application of tensile force, compressive force, bending or shear force or combinations of these forces.*

Classification of metal forming processes:

1. **Based on deformation:**

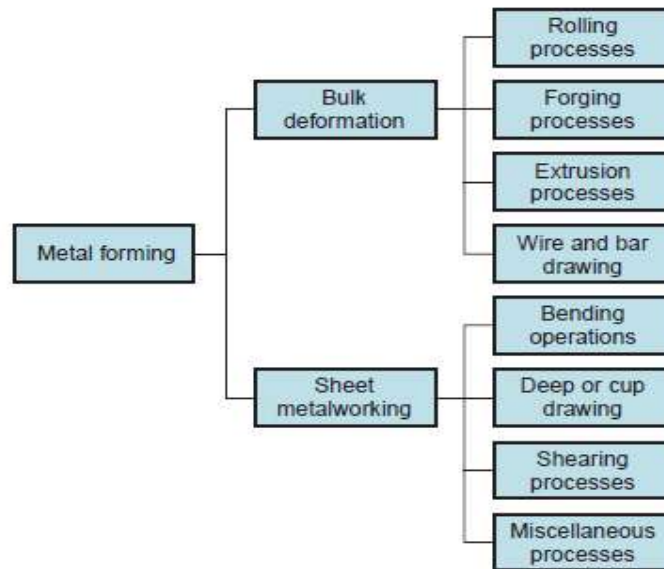

Bulk forming: *It is a severe deformation process resulting in massive shape change. The surface area-to-volume of the work is relatively small. Mostly done in hot working conditions.*

- **Rolling:** In this process, the workpiece in the form of slab or plate is compressed between two rotating rolls in the thickness direction, so that the thickness is reduced. The rotating roll draws the slab into the gap and compresses it. The final product is in the form of sheet.
- **Forging:** The workpiece is compressed between two dies containing shaped contours. The die shapes are imparted into the final part.
- **Extrusion:** In this, the workpiece is compressed or pushed into the die opening to take the shape of the die hole as its cross section.
- **Wire or rod drawing:** similar to extrusion, except that the workpiece is pulled through the die opening to take the cross-section.

Sheet forming: Sheet metal forming involves forming and cutting operations performed on metal sheets, strips, and coils. *The surface area-to-volume ratio of the starting metal is relatively high.* Tools include punch, die that are used to deform the sheets.

- **Bending:** In this, the sheet material is strained by punch to give a bend shape (angle shape) usually in a straight axis.
- **Deep (or cup) drawing:** In this operation, forming of a flat metal sheet into a hollow or concave shape like a cup is performed by stretching the metal in some regions. A blank-holder is used to clamp the blank on the die, while the punch pushes into the sheet metal. The sheet is drawn into the die hole taking the shape of the cavity.
- **Shearing:** This is nothing but cutting of sheets by shearing action.

2. Based on working temperature:

- Cold working
 - Temperature $< 0.3 \times$ melting point in deg. K (Below recrystallization temperature)
 - In practice for most engineering metal this means room temperature.
 - Work hardening is dominant
- Hot working
 - Above the recrystallization temperature
 - Temperature > 0.5 (or 0.6) \times melting point in deg. K
 - Strain rate sensitivity more important
- Warm working
 - Temperature between 0.3 and 0.5 of melting point
 - Flow stresses somewhat less than cold working

Difference between Hot And Cold Working:

- Cold working may be defined as plastic deformation of metals and alloys at a temperature below the recrystallization temperature for that metal or alloy. In cold working process the strain hardening which occurs as a result of mechanical working, does not get relieved. In fact as the metal or alloys gets progressively strain hardened, more and more force is required to cause further plastic deformation. After sometime, if the effect of strain hardening is not removed, the forces applied to cause plastic deformation may cause cracking and failure of material.
- Hot working may be explained as plastic deformation of metals and alloys at such a temperature above recrystallization temperature at which recovery and recrystallization take place simultaneously with the strain hardening.

Advantages and Disadvantages of Cold and Hot Working Processes:

- ❖ As cold working is practically done at room temperature, no oxidation or tarnishing of surface takes place. No scale formation is there, hence there is no material loss where as in hot working, there is scale formation due to oxidation besides, hot working of steel also results in partial decarburization of the work piece surface as carbon gets oxidized as CO_2 .
- ❖ Cold working results in better dimensional accuracy and a bright surface. Cold rolled steel bars are therefore called bright bars, while those produced by hot rolling process are called black bars (they appear greyish black due to oxidation of surface).
- ❖ In cold working heavy work hardening occurs which improves the strength and hardness of bars, and high forces are required for deformation increasing energy consumption. In hot working this is not so.
- ❖ Due to limited ductility at room temperature, production of complex shapes is not possible by cold working processes.
- ❖ Severe internal stresses are induced in the metal during cold working. If these stresses are not relieved, the component manufactured may fail prematurely in service.
- ❖ In hot working, there are no residual internal stresses and the mechanically worked structure is better than that produced by cold working. The strength of materials reduces at high temperature. Its malleability and ductility improve at high temperatures. Hence low capacity equipment is required for hot working processes. The forces on the working tools also reduce in case of hot working processes.

Role of recovery, recrystallization and grain growth:

1. Recovery:

This usually occurs at low temperatures and involves motion and annihilation of point defects as well as annihilation and rearrangement of dislocations resulting in the formation of sub grains and sub grain boundaries (e.g., tilt and/or twist low-angle boundaries). A distinctive feature of the recovery process is that it does not involve any change in the grain structure of the cold-worked metal; the only changes taking place are the dislocation arrangements within the existing grains. Small changes in hardness that are sometimes observed during recovery can be attributed to the decrease in the dislocation and point defect density and to the growth of the sub grains.

2. Recrystallization:

If increased thermal activation is available (i.e., if the temperature is raised) nucleation and growth of strain-free grains in the deformed matrix will take place. As these grains grow, the dislocations in the matrix are annihilated at the boundaries of the newly formed grains. Strength and hardness decrease considerably and ductility increases. The lowest temperature at which stress-free grains appear in the structure of a previously plastically deformed metal is termed the recrystallization temperature. This depends upon the grain size, the severity of plastic deformation, and the presence of solute atoms or second phase particles. The recrystallization temperature is usually 1/3-1/2 the absolute melting point of the material.

3. Grain Growth:

If a recrystallized material is further annealed at the same temperature or at a higher temperature grain growth usually occurs. Boundaries between annealed grains migrate and larger grains grow by an increase in the average grain size (or a decrease in the ASTM grain size number, n). Grain growth depends on the fact that the grain boundary energy of the material is reduced due to the decrease in grain boundary area for a given volume of material. The effect of recovery, recrystallization and grain growth on grain size, internal stress and strength (or hardness) of a plastically deformed material is illustrated schematically in Figure.

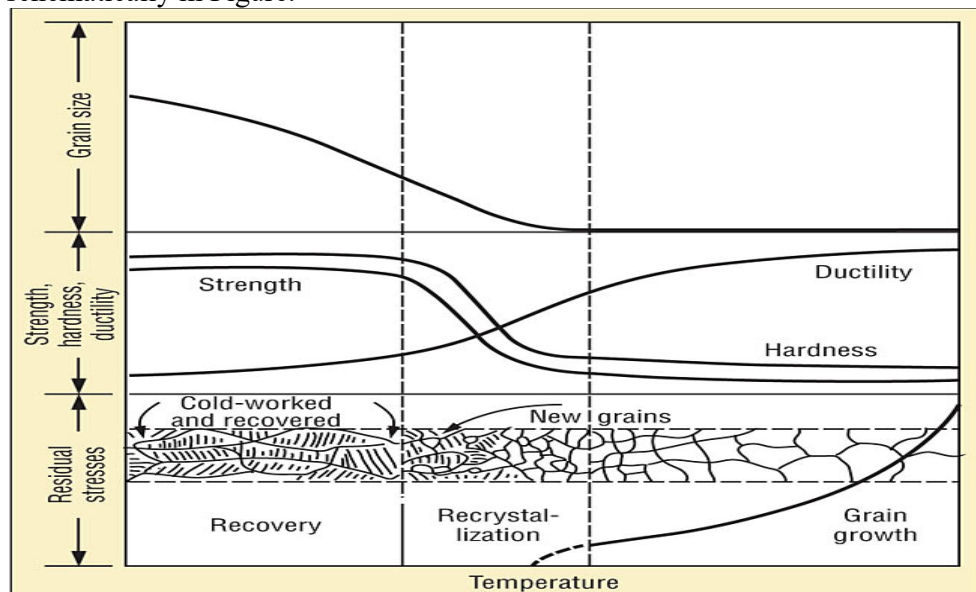

ROLLING PROCESS

Rolling is a deformation process in which the thickness of the work is reduced by compressive forces exerted by two opposing rolls. The rolls rotate to pull and simultaneously squeeze the work between them. The basic process shown in our figure is flat rolling, used to reduce the thickness of a rectangular cross section.

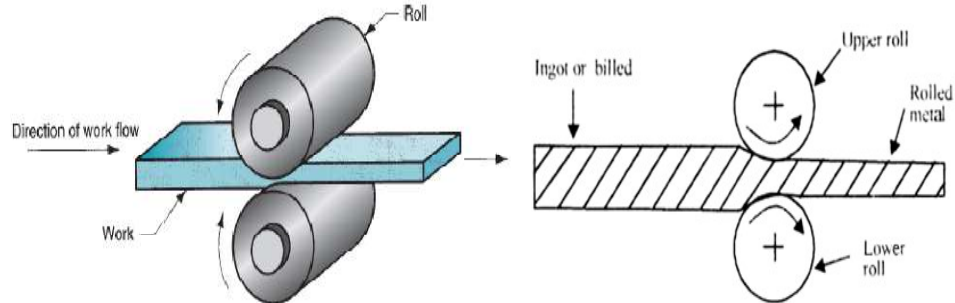

Most rolling processes are very capital intensive, requiring massive pieces of equipment, called rolling mills, to perform them. The high investment cost requires the mills to be used for production in large quantities of standard items such as sheets and plates. Most rolling is carried out by hot working, called hot rolling. The following diagram illustrates few input and output products of rolling process.

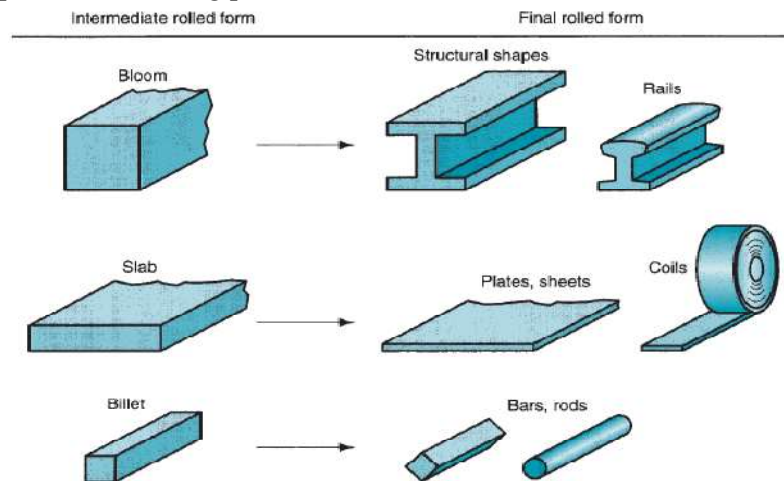

Analysis of rolling process: (Flat Rolling):

Rolling analysis is used to derive the equation for calculating rolling force, roll pressure and power required for rolling process.

Let,

t_o = Initial thickness of slab before rolling, mm

t_f = Final thickness of the slab after rolling, mm

R = Roll radius, mm

V_r = Roll speed, mm/s

V_o = Velocity of slab at entry zone between rollers

V_f = Velocity of slab at exit zone.

L = Contact length or Deformation zone length or Roll contact length.

θ = Bite angle

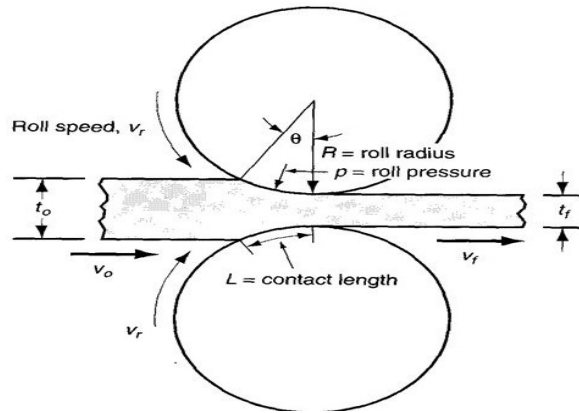

In flat rolling, the work is squeezed between two rolls so that its thickness is reduced by an amount called the draft:

$$\text{Draft, } d = t_o - t_f \text{ ----- 1}$$

Draft is sometimes expressed as a fraction of the starting stock thickness, called the reduction:

$$\text{Reduction, } r = d / t_o \text{ ----- 2}$$

If the change in width of the strip is taken into consideration, we can find the final width by applying the volume constancy principle.

Volume of material before rolling = volume after rolling.

$$t_o w_o l_o = t_f w_f l_f \text{ ----- 3}$$

Where w_o and w_f are the before and after work widths, mm

l_o and l_f are the before and after work lengths, mm.

Similarly, before and after volume rates of material flow must be the same, so the before and after velocities can be related as : $t_o w_o V_o = t_f w_f V_f$ ----- 4

From the diagram above, we note that the velocity of the strip increases from V_o to V_f as it passes through the rolls. This velocity increase takes place in order to satisfy the principle of volume constancy of the billet during the deformation process. Hence

$$t_o w_o V_o = t_f w_f V_f$$

$$(V_o / V_f) = (t_o / t_f) \text{ ----- 5}$$

From equation 5 we find that the strip velocity increases during rolling, as it passes between the rolls. At some section the velocity of rolls and strip velocity are equal. This point is called neutral point.

- Ahead of neutral point, the strip is trailing behind the rolls. Beyond the neutral point the strip leads the rolls.
- Frictional shear stress τ acts tangential to the rolls at any section along the arc of contact between rolls and strip. However, the direction of τ reverses at the neutral point. Between the entry section of the roll gap and the neutral section, the direction of friction is the same as the direction of motion of the strip – into the roll gap.
- Therefore, the friction aids in pulling the strip into the rolls in this part of the travel. The direction of friction reverses after the neutral point, as the velocity of strip is higher than the velocity of the rolls.
- Friction force opposes the forward motion of the strip in sections beyond the neutral section. However, the magnitude of the friction acting ahead of neutral section is greater than that beyond the neutral section.
- Therefore, the net friction is acting along the direction of the strip movement, thereby aiding the pulling of the strip into the roll gap. The forward slip is defined as the difference in velocity between the strip at exit and roll divided by roll velocity.

At roll exit the forward slip is positive, meaning that the work piece moves faster than roll here. The projected arc length L, which is the length of the straight line got by projecting the arc of contact onto a horizontal line or plane. From the geometry of the arc of contact, we can get

$$L^2 = R^2 - (R - d)^2$$

Ignoring power of small quantity, etc, we get

$$\text{Contact Length, } L = \sqrt{R d} \text{ ----- 6}$$

The roll exerts a normal pressure P on the work. This pressure may be imagined to be the pressure exerted by the work piece on the rolls to separating them. Due to the roll pressure a tangential friction shear stress is induced at the interface contact between roll and work piece. This friction stress can be written as:

$$\tau = \mu p \text{ ----- 7}$$

Sliding friction is assumed between roll and work. At the entry section, if the forces acting on the strip are balanced, we get:

$$P \sin\theta = \mu P \cos\theta \rightarrow \text{area over which both forces are acting is the same}$$

If the work piece is to be pulled into the rolls at entry section, the following condition is to be satisfied:

$$\mu p \cos\theta \geq P \sin\theta \rightarrow \mu \geq \tan\theta \rightarrow \tan\theta_{\max} = \mu \text{ ----- 8}$$

Or the minimum condition for work to be pulled into the rolls can be written as: $\mu = \tan\theta$

In rolling metals where all the force is transmitted through the rolls, maximum attainable angle between roll radius at the first contact and the roll centres. If the operating angle is less, it is called the contact angle or roll angle. If the tangent of angle of bite exceeds the coefficient of friction, the work piece will not be drawn into the roll gap $\theta = 0$ indicates rolling. From geometry of the roll-strip contact, we can write:

$$\tan\theta_{\max} = L/(R - d/2) = \sqrt{d/R} = \mu \text{ ----- 9}$$

We can infer from the above equation that for the same angle of bite [same friction condition], a larger roll will enable thicker slab to be drawn into the roll gap. This is because for large radius roll the arc length is larger, and hence L is larger. From equation 9 above we find:

$$d_{\max} = \mu^2 R \text{ ----- 10}$$

From equation 10 we can conclude that decreasing the roll radius reduces the maximum achievable reduction in thickness of strip. We can also conclude that higher coefficient of friction can allow larger thickness of the strip to be drawn into the roll throat. Longitudinal grooves are made on the roll surface in order to increase friction. This enables the breakdown of large thickness ingots during hot rolling.

Example 1: What is the maximum possible reduction that could be achieved on a strip of 250 mm thick, if it is cold rolled using rolls of diameter 600 mm with a coefficient of friction value of 0.09. What is the corresponding thickness if the rolling is carried out hot with $\mu = 0.5$? Consider an elemental strip within the deformation zone, as shown below:

The true strain experienced by the work in rolling is based on before and after stock thicknesses. In equation form,

$$\epsilon = \ln(t_0/t_f) \text{ ----- 11}$$

The true strain can be used to determine the average flow stress Y_f , applied to the work material in flat rolling.

$$Y_f = \frac{K\epsilon^n}{1+n} \text{ ----- 12}$$

Given a coefficient of friction sufficient to perform rolling, roll force F required to maintain separation between the two rolls can be computed by following equation:

$$F = Y_f w L \text{ ----- 13}$$

The torque in rolling can be estimated by assuming that the roll force is centred on the work as it passes between the rolls, and that it acts with a moment arm of one-half the contact length L .

$$T = 0.5 F L \quad \text{--- 14}$$

The power required to drive the each roll is the product of torque and angular velocity. Angular velocity is $2\pi N$, where N is the rotational speed of the roll. Thus the power for each roll is $2\pi NT$. Substituting the equation for torque in this expression for power and doubling the value to account for the fact that a rolling mill consists of two powered rolls, following expression may be used to compute the power

$$P = 2\pi NFL \quad \text{--- 15}$$

Example 2: A 40 mm thick plate is to be reduced to 30 mm in one pass in a rolling operation. Entrance speed = 16 m/min. Roll radius = 300 mm, and rotational speed = 18.5 rev/min. Determine: (a) the minimum required coefficient of friction that would make this rolling operation possible, (b) exit velocity under the assumption that the plate widens by 2% during the operation, and (c) forward slip.

Example 3: A series of cold rolling operations are to be used to reduce the thickness of a plate from 50 mm down to 25 mm in a reversing two-high mill. Roll diameter = 700 mm and coefficient of friction between rolls and work = 0.15. The specification is that the draft is to be equal on each pass. Determine: (a) minimum number of passes required, and (b) draft for each pass?

Roll mill configurations:

- Two-high: two opposing rolls two opposing rolls
- Three-high: work passes through rolls in both directions work passes through rolls in both directions
- Four-high: backing rolls support smaller work rolls backing rolls support smaller work rolls
- Cluster mill: multiple backing rolls on smaller rolls multiple backing rolls on smaller rolls
- Tandem rolling mill: sequence of two-high mills

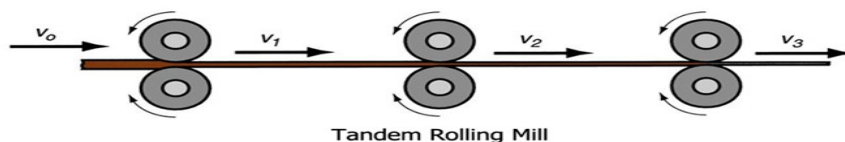
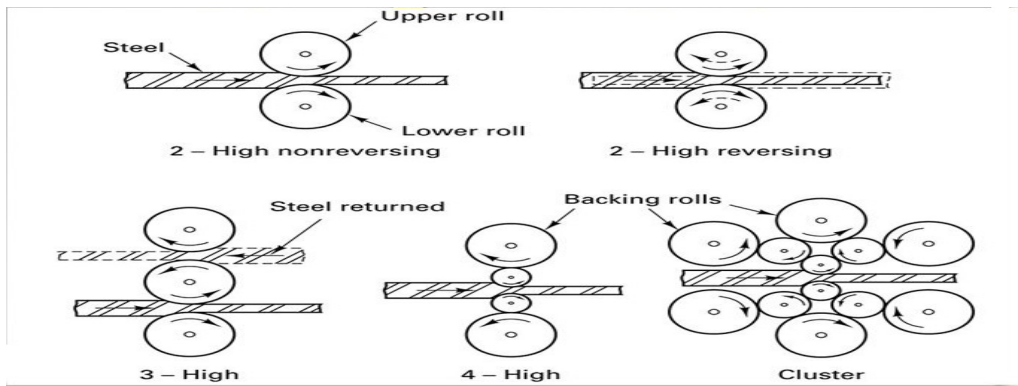

Rolling defects: Small thickness sheets are more sensitive to roll gap defects leading to greater defects. Thin strips are more likely to undergo waviness or buckling. These defects are corrected by doing roller leveling or stretch leveling under tension. Stretch leveling is carried out between roller leveler rolls.

Wavy edges: Flatness of rolled sheets depends on the roll deflection. Sheets become wavy as roll deflection occurs. If rolls are elastically deflected, the rolled sheets become thin along the edge, whereas at centre, the thickness is higher. Similarly, deflected rolls result in longer edges than the centre.

- Edges of the sheet elongate more than the centre. Due to continuity of the sheet, we could say that the centre is subjected to tension, while edges are subjected to compression. This leads to waviness along edges.



Wavy edge

- If rolls are elastically deflected, the rolled sheets become thin along the edge, whereas at centre, the thickness is higher. Similarly, deflected rolls result in longer edges than the centre.
- Edges of the sheet elongate more than the centre. Due to continuity of the sheet, we could say that the centre is subjected to tension, while edges are subjected to compression. This leads to waviness along edges.
- Cambering of rolls can prevent such defects. However, one camber works out only for a particular roll force.

Centre buckle: If rolls have excess convexity then the center of the sheet metal will have more elongation than the edges. This leads to a defect called centre buckle.



Edge Cracks: During rolling the sheet will have a tendency to deform in lateral direction. Friction is high at the centre. Therefore, spread is the least at the centre. This leads to rounding of ends of the sheet. The edges of the sheet are subjected to tensile deformation. This leads to edge cracks.



Centre split/ Centre crack: If the center of the sheet is severely restrained and subjected to excess tensile stress, center split may happen. Along the centre **zipper cracks** occur due to high tensile stress there

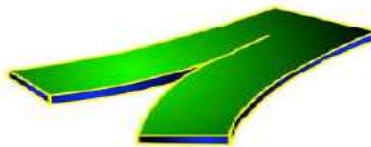

Residual stress in rolling:

Compressive stress is induced on the surface of rolled product if small diameter rolls are used or if smaller reductions are affected during rolling. Stress in the bulk of the strip is tensile in the above case. Larger reductions or rolling using large diameter rolls leads to tensile stress on the skin and compressive stress in the bulk of the metal. Stress relieving operation can be used to relieve the residual stresses of rolled products.

Drawing Process

Drawing is a metal forming process used to reduce cross section and increase length of work piece. This process associated with tensile force which distinguishes it from other metal forming processes like extrusion, forging etc. In this process a large cross section work piece is forced to pass through a die which has smaller opening comparing cross section area of work piece. This will plastically deform the work piece by decreasing its cross section area and increases its length. This process is used for making wires, rods, tubes etc.

Requirement of Drawing Process:

- The material should have sufficient ductility so it can sustain tensile force.
- The material should possess high tensile stress.
- The rod or wire should be properly cleaned and dust or scale free before drawing.
- It should be properly lubricated to reduce friction associated with operation.

General Drawing process section is as shown in figure:

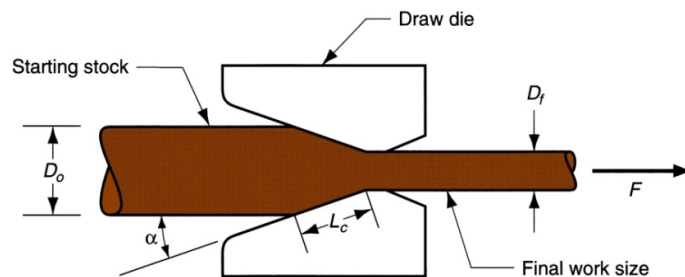

Wire Drawing:

A wire is a circular, small diameter flexible rod. Wire drawing is an cold working process. It is an operation to produce wire of various sizes within certain specific tolerances. This process involves reducing diameter of thick wire by passing it through a series of wire drawing dies with successive die having smaller diameter than the preceding one. Mostly die are made by chilled cast iron, tungsten carbide, diamond or other tool material. The maximum reduction in area of wire is less than 45% in one pass.

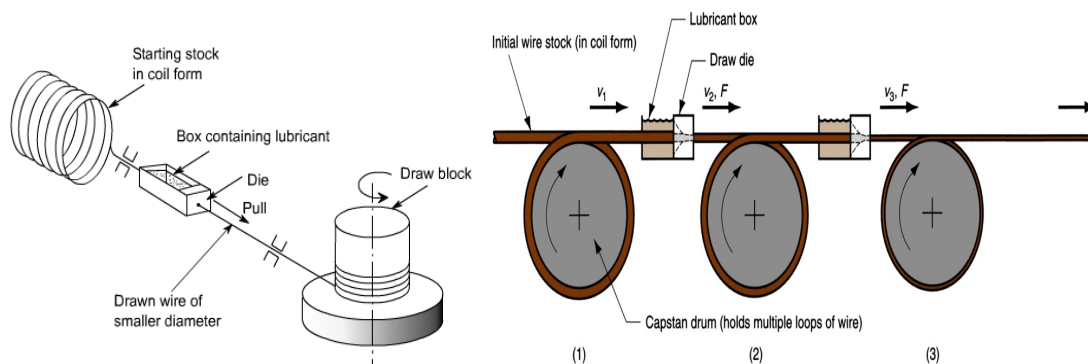

Rod Drawing:

Rod drawing is similar process like wire drawing except it is rigid and has larger diameter compare to wire. This process need heavier equipment compare to wire drawing because the wire can be coiled but a rod should be kept straight. The work piece is first fed into die and pulled by a carriage which increase its length and decrease its cross section. Now the rod is to be cut into sections.

Tube Drawing:

Tube drawing is also similar to other two processes except it uses a mandrel to reduce wall thickness and cross section diameter of a tube. This mandrel placed with die and the work piece is pulled by a carriage system as describe in rod drawing. The tube is either circular or rectangular. It also required more than one pass to complete drawing operation.

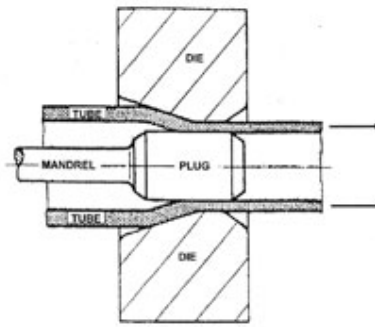

Analysis of Drawing Process:

If no friction or redundant work occurred in drawing, true strain could be determined as follows:

$$\epsilon = \ln \left(\frac{A_0}{A_f} \right) = \ln \left(\frac{1}{1-r} \right)$$

Where, A_0 and A_f are the original and final cross-sectional areas of the work, as previously defined; and r is drawing reduction as given by, $r = \frac{A_0 - A_f}{A_0}$

The stress that results from this ideal deformation is given by: $\sigma = \bar{\sigma}_f \epsilon$

Where $\bar{\sigma}_f = K \frac{\epsilon^n}{1+n}$ = average flow stresses

Because friction is present in drawing and the work metal experiences inhomogeneous deformation, the actual stress is larger than provided. In addition to the ratio A_0/A_f , other variables that influence draw stress are die angle and coefficient of friction at the work–die interface:

$$\sigma = \bar{\sigma}_f \left(1 + \frac{\mu}{\tan \alpha} \right) \Phi \ln \left(\frac{A_0}{A_f} \right)$$

Where σ = draw stress, MPa

μ = coefficient of friction, α = half die angle

Φ = factor that accounts for inhomogeneous = $0.88 + 0.12 \left(\frac{D}{L_c} \right)$

D = mean diameter = $(D_o + D_f)/2$

$L = (D_o - D_f)/2 \sin \alpha$

The corresponding draw force is then the area of the drawn cross section multiplied by the draw stress:

$$F = A_f \sigma$$

Example: Wire is drawn through a draw die with entrance angle 15° . Starting diameter is 2.5mm and final diameter to 2.0 mm. The coefficient of friction at the work–die interface is 0.07. The metal has a strength coefficient $K = 205$ MPa and a strain-hardening exponent $n = 0.20$. Determine the draw stress and draw force in this operation.

Drawing defects: Typical defects in a drawn rod or wire are similar to those observed in extrusion especially centre cracking another major type of defect in drawing is seams, which are longitudinal scratches or folds in the material.

Seams may open up during subsequent forming operations (such as upsetting, heading, thread rolling, or bending of the rod or wire), and they can cause serious quality-control problems. Various other surface defects (such as scratches and die marks) also can result from improper selection of the process parameters, poor lubrication, or poor die condition.

Extrusion Process

Working Principle: Extrusion is a simple compressive metal forming process. In this process, piston or plunger is used to apply compressive force at work piece. This process can be summarized as follow.

Steps:

- First billet or ingot (metal work piece of standard size) is produced.
- This billet is heated in hot extrusion or remains at room temperature and placed into a extrusion press (Extrusion press is like a piston cylinder device in which metal is placed in cylinder and pushed by a piston. The upper portion of cylinder is fitted with die).
- Now a compressive force is applied to this part by a plunger fitted into the press which pushes the billet towards die.
- The die is small opening of required cross section. This high compressive force allow the work metal to flow through die and convert into desire shape.
- Now the extruded parts remove from press and are heat treated for better mechanical properties.

Types of Extrusion: Extrusion process can be classified into following types.(According to the direction of flow of metal)

Direct Extrusion: In this type of extrusion process, metal is forced to flow in the direction of feed of punch. The punch moves toward die during extrusion. This process required higher force due to higher friction between billet and container.

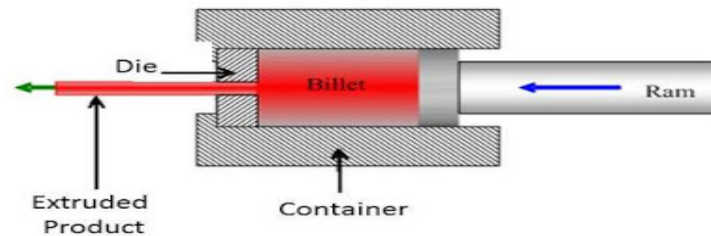

Direct Extrusion

Indirect Extrusion: In this process, metal is flow toward opposite direction of plunger movement. The die is fitted at opposite side of punch movement. In this process, the metal is allowed to flow through annular space between punch and container.

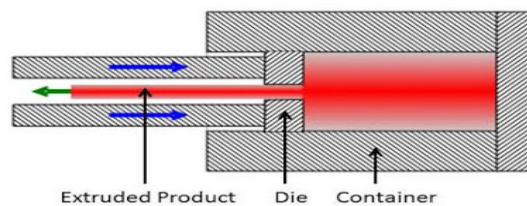

Indirect Extrusion

Hydrostatic Extrusion: This process uses fluid to apply pressure on billet. In this process, the friction is eliminated because the billet is neither contact with cylinder wall or plunger. There is a fluid between the billet and plunger. The plunger applies force on fluid which further applied on billet. Normally vegetable oils are used as fluid. This process accomplished by leakage problem and uncontrolled speed of extrusion.

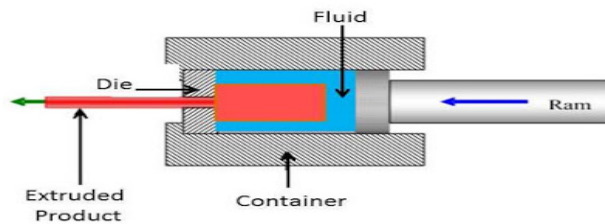

Hydrostatic Extrusion

Impact Extrusion: Impact extrusion is performed at higher speeds and shorter strokes than conventional extrusion. It is used to make individual components. As the name suggests, the punch impacts the work part rather than simply applying pressure to it. Impacting can be carried out as forward extrusion, backward extrusion, or combinations of these.

Impact extrusion is usually done cold on a variety of metals. Backward impact extrusion is most common. Products made by this process include toothpaste tubes and battery cases. As indicated by these examples, very thin walls are possible on impact extruded parts. The high-speed characteristics of impacting permit large reductions and high production rates, making this an important commercial process.

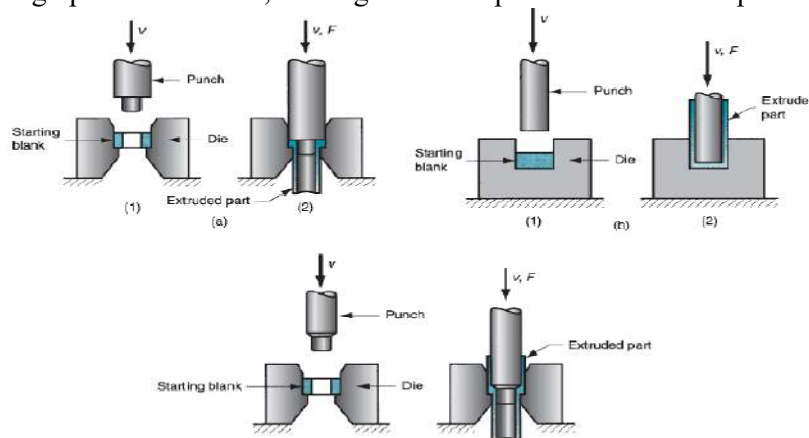

Application:

- Extrusion is widely used in production of tubes and hollow pipes.
- Aluminum extrusion is used in structure work in many industries.
- This process is used to produce frames, doors, window etc. in automotive industries.
- Extrusion is widely used to produce plastic objects.

Advantages:

- High extrusion ratio (It is the ratio of billet cross section area to extruded part cross section area).
- It can easily create complex cross section.
- This working can be done with both brittle and ductile materials.
- High mechanical properties can achieve by cold extrusion.

Disadvantages:

- High initial or setup cost.
- High compressive force required.

Analysis of extrusion:

Let us use Figure as a reference in discussing some of the parameters in extrusion. The diagram assumes that both billet and extrudate are round in cross section. One important

parameter is the extrusion ratio, also called the reduction ratio. The ratio is defined:

Reduction or Extrusion ratio,
$$r = \frac{A_0}{A_f}$$

A_0 = cross-sectional area of the starting billet, mm²

A_f = final cross-sectional area of the extruded section, mm²

The ratio applies for both direct and indirect extrusion the value of r can be used to determine true strain in extrusion, given that ideal deformation occurs with no friction and no redundant work:

$$\epsilon = \ln(r) = \ln\left(\frac{A_0}{A_f}\right)$$

Under the assumption of ideal deformation (no friction and no redundant work), the pressure applied by the ram to compress the billet through the die opening depicted in our figure can be computed as follows:

$$p = \bar{\sigma}_f \ln(r)$$

$\bar{\sigma}_f$ = Average flow stresses

For frictional case: Friction exists between the die and the work as the billet squeezes down and passes through the die opening. In direct extrusion, friction also exists between the container wall and the billet surface. The following empirical equation proposed by Johnson for estimating extrusion strain (in friction condition):

$$\epsilon = a + b \ln(r)$$

ϵ = extrusion strain

a and b are empirical constants for a given die angle.

Typical values of these constants are: a = 0.8 and b = 1.2 to 1.5.

Values of a and b tend to increase with increasing die angle.

Indirect extrusion, the ram pressure to perform can be estimated based on Johnson's extrusion strain formula as follows:

$$p = \bar{\sigma}_f \epsilon$$

In direct extrusion, the effect of friction between the container walls and the billet causes the ram pressure to be greater than for indirect extrusion, the following formula can be used to compute ram pressure in direct extrusion:

$$p = \bar{\sigma}_f \left(\epsilon + \frac{2L}{D_0} \right)$$

L is the portion of the billet length remaining to be extruded

D_0 is the original diameter of the billet.

Ram force in indirect or direct extrusion is simply pressure p multiplied by billet area A_0

$$F = p A_0$$

Example: A billet 75mm long and 25mm diameter is to be extruded in a direct extrusion operation with extrusion ratio $r = 4.0$. The extrudate has a round cross section. The die angle (half angle) = 90°. The work metal has a strength coefficient = 415 MPa, and strain-hardening exponent = 0.18. Use the Johnson formula with a = 0.8 and b = 1.5 to estimate extrusion strain. Determine the pressure applied to the end of the billet as the ram moves forward.

Defects In Extrusion process:

(a) Center burst. This defect is an internal crack that develops as a result of tensile stresses along the centerline of the work part during extrusion. Although tensile stresses may seem unlikely in a compression process such as extrusion, they tend to occur under conditions that cause large deformation in the regions of the work away from the central axis. The significant material movement in these outer regions stretches the material along the center of the work. If stresses are great enough, bursting occurs. Conditions that promote center burst are high die angles, low extrusion ratios, and impurities in the work metal that serve as starting points for crack defects. The difficult aspect of center burst is its detection. It is an internal defect that is usually not noticeable by visual observation. Other names sometimes used for this defect include arrowhead fracture, center cracking, and chevron cracking.

(b) Piping. Piping is a defect associated with direct extrusion. It is the formation of a sink hole in the end of the billet. The use of a dummy block whose diameter is slightly less than

that of the billet helps to avoid piping. Other names given to this defect include tailpipe and fishtailing.

(c) Surface cracking. This defect results from high workpart temperatures that cause cracks to develop at the surface. They often occur when extrusion speed is too high, leading to high strain rates and associated heat generation. Other factors contributing to surface cracking are high friction and surface chilling of high temperature billets in hot extrusion.

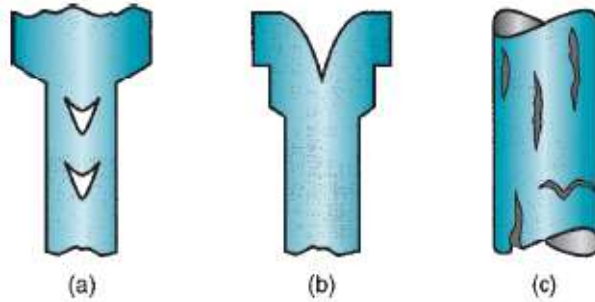

Manufacturing Processes

UNIT-VI

Forging is a deformation processing of materials through compressive stress. It is carried out either hot or cold. Typical applications of forging include bolts, disks, gears, turbine disk, crank shaft, connecting rod, valve bodies, small components for hydraulic circuits etc. Forging has several advantages. Closer dimensional accuracies achieved require very little machining after forging. Material saving is the result. Higher strength, greater productivity, favourable grain orientation, high degree of surface finish is other merits. However, complex die making is costly.

Types of forging:

- Based on the type of loading, forging is classified as :

Press forging. (Involves gradual loads.):

Depending upon type of energy used press forging is classified as :

1. Mechanical Press
2. Hydraulic Press

Hydraulic Press:-

- Using a hydraulic press or a mechanical press to forge the metal, therefore, gives continuous forming at a slower rate.
- The load is applied on the work piece gradually.
- Hydraulic presses are load-restricted machines in which hydraulic pressure moves a piston in a cylinder.
- The full press load is available at any point during the full stroke of the ram. Therefore, hydraulic presses are ideally suited for extrusion-type forging operation.
- Due to slow speed, contact time is longer at the die-metal interface, which causes problems such as heat lost from work-piece and die deterioration.
- Also provide close-tolerance forging.
- Hydraulic presses are more expensive than mechanical presses and hammers.

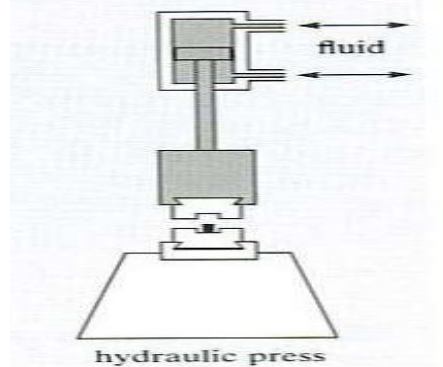

Following are the examples for mechanical press forging set up:

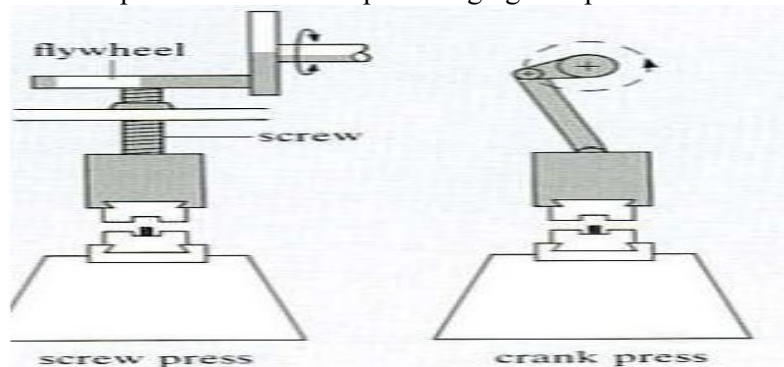

Drop (or) Hammer forging (Involves impact load):

- The upper die and ram are raised by friction rolls gripping the board. • After releasing the board, the ram falls under gravity to produce the blow energy.
- The hammer can strike between 60-150 blows per minute depending on size and capacity.
- The blow energy supplied equals the potential energy due to the weight and the height of the fall.
- This energy will be delivered to the metal workpiece to produce plastic deformation.
- Provide rapid impact blows to the surface of the metal.
- Energy (from a gravity drop) is adsorbed onto the metal, in which the maximum impact is on the metal surface.
- Dies are expensive being accurately machined from special alloys (susceptible to thermal shock).
- Drop forging is good for mass production of complex shapes.

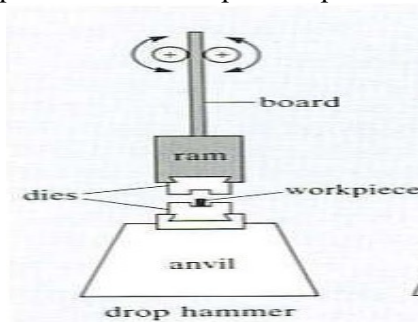

Roll forging: Roll forging or roll forming is a forging technique that utilizes opposing rolls to shape a metal part. Even though roll forging uses rolls in order to accomplish the deformation of the material, it is classified as a metal forging process and not a rolling process. More similarly to metal forging than metal rolling, it is a discrete process and not a continuous one. Roll forging is usually performed hot. The precisely shaped geometry of grooves on the roll, forge the part to the required dimensions. The forging geometry of the rolls used to forge metal parts is only present over a portion of the roll's circumference. Only part of a full revolution of a roll is needed to forge the work piece. Typically in manufacturing industry, the forging geometry on the rolls may occupy from one quarter to three quarters of the roll's circumference.

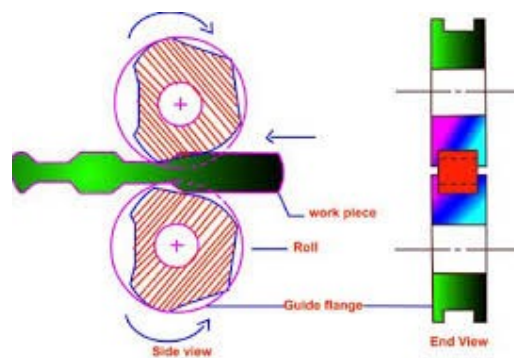

- Based on the nature of material flow and constraint on flow by the die/punch, forging is classified as :
 1. **Open die forging:** Open die forging: In this, the work piece is compressed between two platens. There is no constraint to material flow in lateral direction. Upsetting is an

open die forging in which the billet is subjected to lateral flow by the flat die and punch. Due to friction the material flow across the thickness is non uniform. Material adjacent to the die gets restrained from flowing, whereas, the material at center flows freely. This causes a phenomenon called barrelling in upset forging.

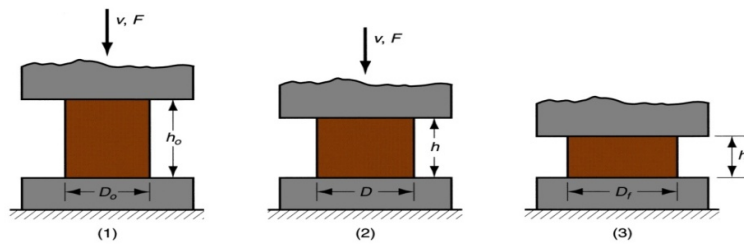

2. **Impression die forging:** Impression die forging both die and punch have impressions, shapes which are imparted onto the work piece. There is more constrained flow in this process. Moreover, the excess metal flows out of the cavity, forming flash.

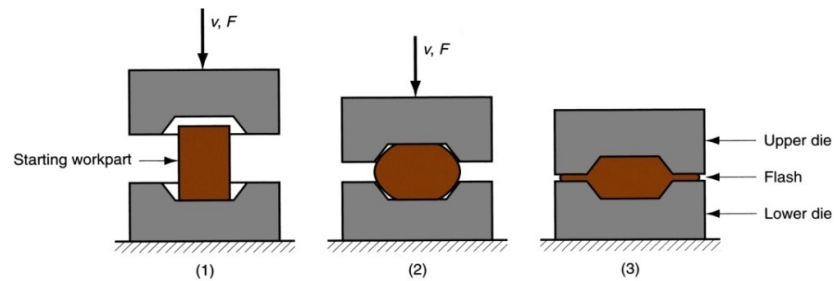

3. **Flashless forging:** In this the work piece is totally constrained to move within die cavity. No excess material and hence no flash forms. Flashless forging involves high level of accuracy. Designs of shape of die cavity, finished product volume are important

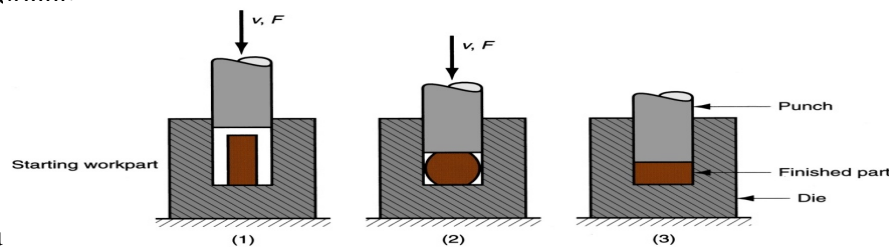

Edging is u

in the horizontal direction but it is free to flow laterally to fill the die.

fin

Edging

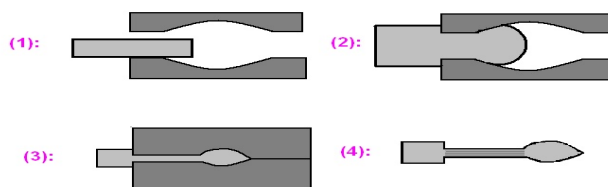

Fullering is used to reduce the cross-sectional area of a portion of the stock. The metal flow is outward and away from the centre of the fuller. i.e. forging of connecting rod for an internal combustion engine.

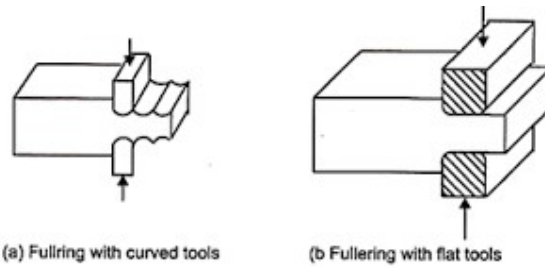

Swaging is used to produce a bar with a smaller diameter (using concave dies). Swaging is a special type of forging in which metal is formed by a succession of rapid hammer blows. Swaging is a special type of forging in which metal is formed by a succession of rapid hammer blows.

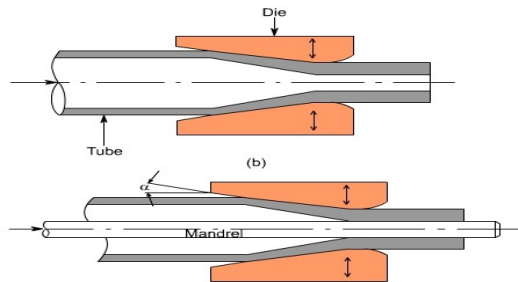

Heading: Heads of bolts, nails are made by heading, which is an upsetting process. Special types of machines are used for heading.

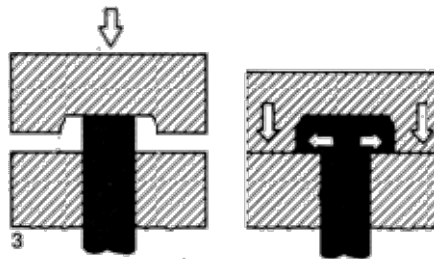

Roll forging: In this process, the bar stock is reduced in cross-section or undergoes change in cross-section when it is passed through a pair of grooved rolls made of die steel. This process serves as the initial processing step for forging of parts such as connecting rod, crank shaft etc. Finished products like tapered shafts, leaf springs can also be made.

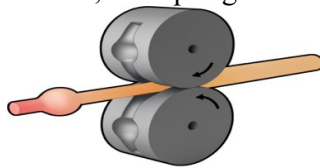

Analysis of Open-Die Forging: If open-die forging is carried out under ideal conditions of no friction between works and dies surfaces, then homogeneous deformation occurs, and the radial flow of the material is uniform throughout its height. Under these ideal conditions, the true strain experienced by the work during the process can be determined by:

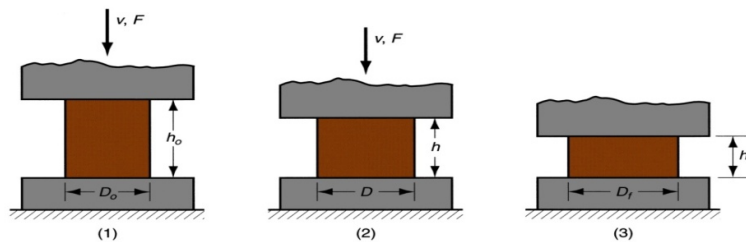

$$\epsilon = \ln \left(\frac{h_o}{h} \right)$$

Where h_o = starting height of the work, mm

h = the height at some intermediate point in the process, mm

Estimates of force to perform upsetting can be calculated. The force required to continue the compression at any given height h during the process can be obtained by multiplying the corresponding cross-sectional area by the flow stress:

$$F = \sigma_f A$$

An actual upsetting operation does not occur quite as earlier because friction opposes the flow of work metal at the die surfaces. This creates the barreling effect shown in Figure.

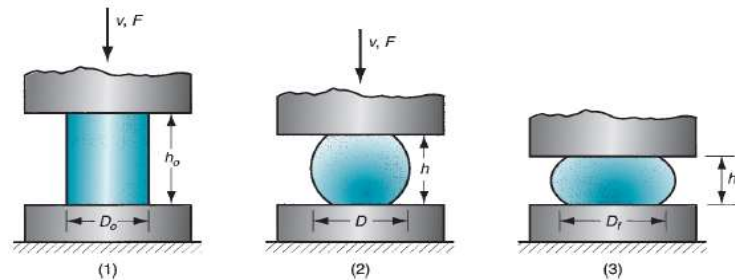

When performed on a hot work part with cold dies, the barreling effect is even more pronounced. This results from a higher coefficient of friction typical in hot working and heat transfer at and near the die surfaces, which cools the metal and increases its resistance to deformation. The hotter metal in the middle of the part flows more readily than the cooler metal at the ends. These effects are more significant as the diameter-to-height ratio of the workpart increases, due to the greater contact area at the work–die interface. All of these factors because the actual upsetting force to be greater to account for effects of the D/h ratio and friction:

$$F = K_f \sigma_f A$$

$$K_f = \left(1 + \frac{0.4 \mu D}{h}\right)$$

μ = coefficient of friction; D = workpart diameter or other dimension representing contact length with die surface, mm and h = workpart height, mm

Example: A cylindrical workpiece is subjected to a cold upset forging operation. The starting piece is 75 mm in height and 50 mm in diameter. It is reduced in the operation to a height of 36mm. The work material has a flowcurve defined by $K = 350\text{MPa}$ and $n = 0.17$. Assume a coefficient of friction of 0.1. Determine the force as the process begins, at intermediate heights of 62mm, 49 mm, and at the final height of 36 mm.

SHEET METAL FORMING

Sheet metal processing is an important process for many industries, producing home appliances (fridge, washer, dryer, vacuum cleaners etc.), electronics (DVD- and CD-players, stereos, radios, amplifiers etc.), toys and PC's. Most of these products have metal casings that are made by cutting and bending sheet metal. We look at some of the basic sheet metal cutting and forming processes.

- The operations are performed on relatively thin sheets of metal:
- Thickness of sheet metal = 0.4 mm to 6 mm
- Thickness of plate stock > 6 mm
- Operations usually performed as cold working

Sheet metal operations:

1. Cutting –
 - Shearing to separate large sheets
 - Blanking to cut part perimeters out of sheet metal
 - Punching to make holes in sheet metal
2. Bending :- Straining sheet around a straight axis
3. Drawing :- Forming of sheet into convex or concave shapes

Cutting Operations:

1. Shearing Sheet metal cutting operation along a straight line between two cutting edges. Typically used to cut large sheets.

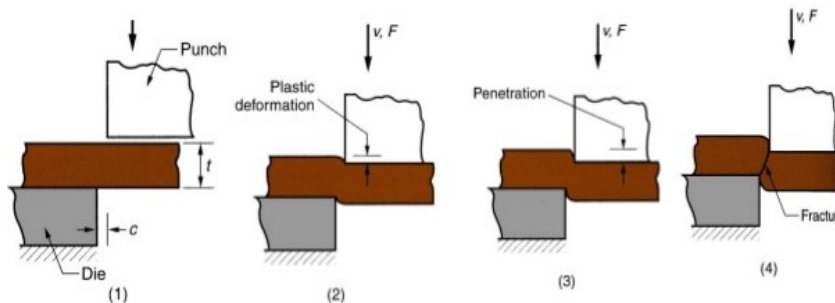

2. Punching - sheet metal cutting operation where the cut piece is scrap.
3. Blanking - sheet metal cutting to separate piece (called a blank) from surrounding stock

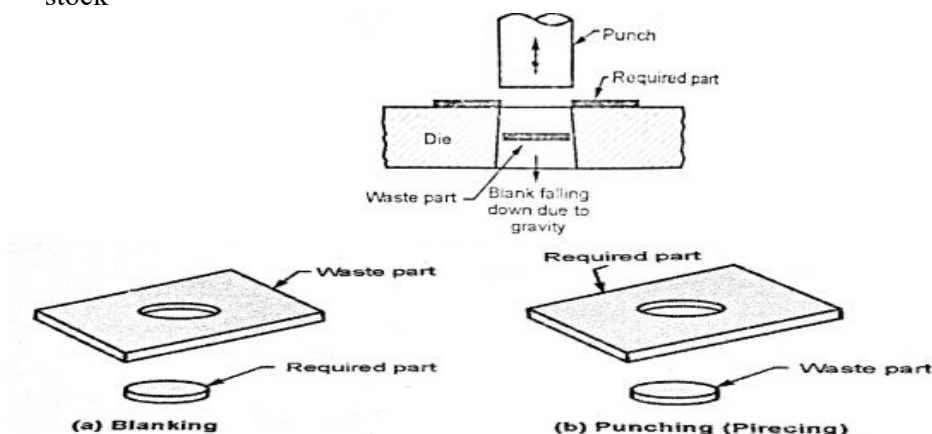

Analysis of Sheet-Metal Cutting: Process parameters in sheet-metal cutting are clearance between punch and die, stock thickness, type of metal and its strength, and length of the cut. Typical clearances in conventional press working range between 4% and 8% of the sheet-metal thickness t . If the clearance is too small, then the fracture lines tend to pass each other, causing a double burnishing and larger cutting forces. If the clearance is too large, the metal becomes pinched between the cutting edges and an excessive burr results. The recommended clearance can be calculated by the following formula: $C = A_c t$

A_c = clearance allowance; and t = stock thickness, mm

$A_c = 0.045$ for Aluminum and its alloys.

= 0.060 for 6061STaluminum alloys, Brass, Soft cold rolled steel, Stainless Steel.

= 0.075 for Cold-rolled steel, hard stainless steel.

The die opening must always be larger than the punch size (obviously). Whether to add the clearance value to the die size or subtract it from the punch size depends on whether the part being cut out is a blank or a slug, as illustrated in the figure for a circular part. Because of the geometry of the sheared edge, the outer dimension of the part cut out of the sheet will be larger than the hole size. Thus, punch and die sizes for a round blank of diameter D_b are determined as

- Blanking punch diameter = $D_b - 2c$
- Blanking die diameter = D_b
- Punch and die sizes for a round hole of diameter D_h are determined as:
- Hole punch diameter = D_h
- Hole die diameter = $D_h + 2c$

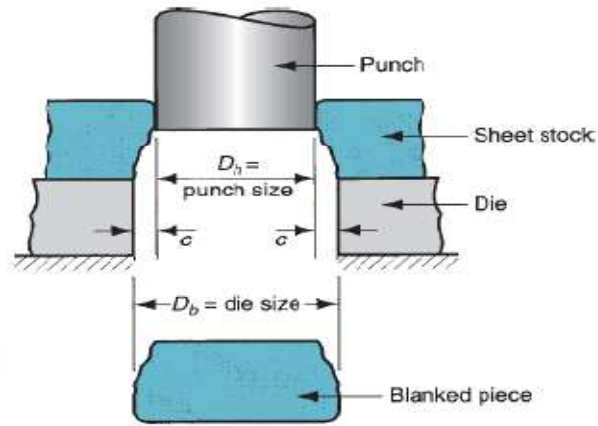

Cutting force F in sheet metalworking can be determined by: $F = \tau t L$

Where τ = shear strength of the sheet metal, MPa

t = stock thickness, mm

L = length of the cut edge, mm

In blanking, punching, slotting, and similar operations, L is the perimeter length of the blank or hole being cut.

Example: Around disk of 150-mm diameter is to be blanked from a strip of 3.2-mm, half-hard cold rolled steel whose shear strength = 310 MPa. Determine (a) the appropriate punch and die diameters (b) blanking force

Bending:

- Straining sheet metal around a straight axis to take a permanent bend.
- Metal on inside of neutral plane is compressed, while metal on outside of neutral plane is stretched

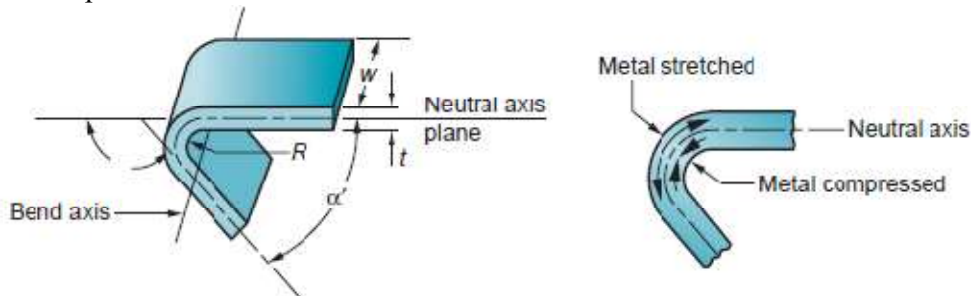

Types of Sheet Metal Bending:

1. V-bending - performed with a V-shaped die

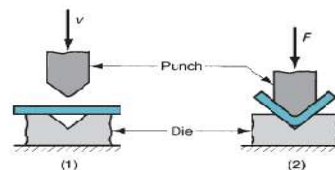

2. Edge bending - performed with a wiping die

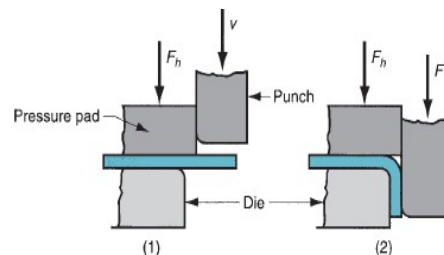

Bend Allowance: If the bend radius is small relative to stock thickness: the metal tends to stretch during bending. It is important to be able to estimate the amount of stretching that occurs, if any, so that the final part length will match the specified dimension. The problem is to determine the length of the neutral axis before bending to account for stretching of the final bent section. This length is called the bend allowance, and it can be estimated as follows:

$$A_b = 2\pi \frac{\alpha}{360} R + K_{ba} t$$

where A_b = bend allowance, mm

α = bend angle, degrees, R = bend radius, mm, t = stock thickness, mm;

K_{ba} is factor to estimate stretching. if $R < 2t$, $K_{ba} = 0.33$;

if $R \geq 2t$, $K_{ba} = 0$

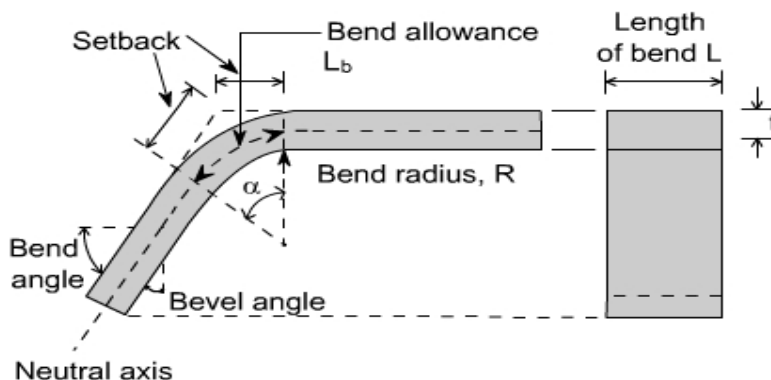

Springback: When the bending pressure is removed at the end of the deformation operation, elastic energy remains in the bent part, causing it to recover partially toward its original shape. This elastic recovery is called springback, defined as the increase in included angle of the bent part relative to the included angle of the forming tool after the tool is removed.

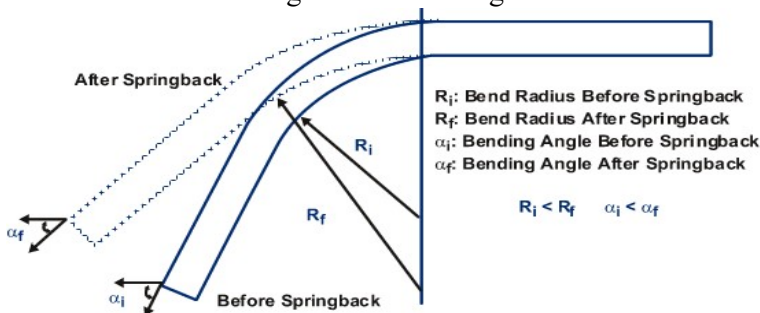

Bending Force: The force required to perform bending depends on the geometry of the punch-and-die and the strength, thickness, and length of the sheet metal. The maximum bending force can be estimated by means of the following equation:

$$F = \frac{K_{bf}(TS)Wt^2}{D}$$

Where F = bending force, N

TS = tensile strength of the sheet metal, MPa

W = width of part in the direction of the bend axis, mm

t = stock thickness, mm (in)

D = die opening dimension

For V-bending, $K_{bf} = 1.33$; and for edge bending, $K_{bf} = 0.33$.

Example: A sheet-metal blank is to be bent as shown in Figure 20.15. The metal has a modulus of elasticity = $205 (10^3)$ MPa, yield strength = 275 MPa, and tensile strength = 450 MPa. Determine (a) the starting blank size and (b) the bending force if a V-die is used with a die opening dimension = 25 mm.

Deep Drawing: Drawing is a sheet-metal-forming operation used to make cup-shaped, box-shaped, or other complex-curved and concave parts. It is performed by placing a piece of sheet metal over a die cavity and then pushing the metal into the opening with a punch. The blank must usually be held down flat against the die by a blank holder. Common parts made by drawing include beverage cans, ammunition shells, sinks, cooking pots, and automobile body panels.

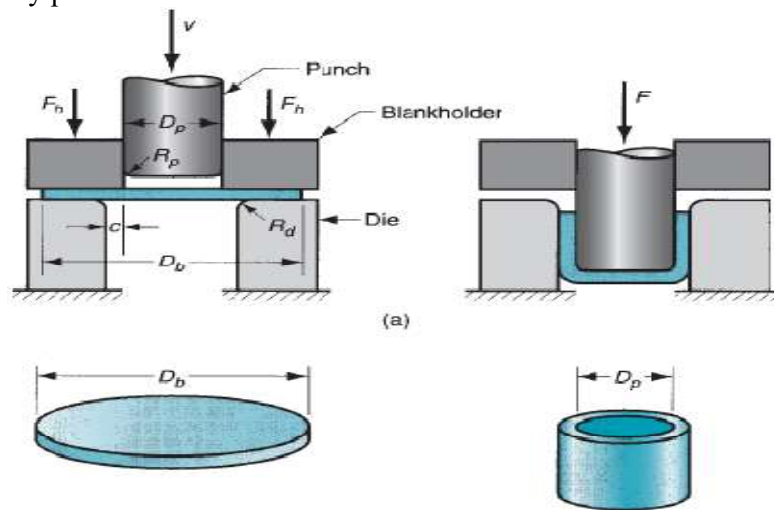

Analysis of deep drawing:

Drawing of a cup-shaped part is the basic drawing operation. A blank of diameter D_b is drawn into a die cavity by means of a punch with diameter D_p . The punch and die must have corner radii, given by R_p and R_d . If the punch and die were to have sharp corners (R_p and $R_d = 0$), a hole-punching operation (and not a very good one) would be accomplished rather than a drawing operation. The sides of the punch and die are separated by a clearance c . This clearance in drawing is about 10% greater than the stock thickness: $C = 1.1 t$

One of the measures of the severity of a deep drawing operation is the drawing ratio DR. This is most easily defined for a cylindrical shape as the ratio of blank diameter D_b to punch diameter D_p . In equation form,

$$DR = \frac{D_b}{D_p}$$

Another way to characterize a given drawing operation is by the reduction r , where,

$$r = \frac{D_b - D_p}{D_b}$$

The drawing force required to perform a given operation can be estimated roughly by the formula:

$$F = \pi D_p t (TS) \left(\frac{D_b}{D_p} - 0.7 \right)$$

The holding force is an important factor in a drawing operation. As a rough approximation, the holding pressure can be set at a value $\frac{1}{4}$ 0.015 of the yield strength of the sheet metal. This value is then multiplied by that portion of the starting area of the blank that is to be held by the blankholder.

$$F_h = 0.015 \sigma \pi \{ D_b^2 - (D_p + 2.2t + 2R_d)^2 \}$$

Example: A drawing operation is used to form a cylindrical cup with inside diameter = 75 mm and height = 50mm. The starting blank size = 138mm and the stock thickness = 2.4mm. Based on these data, is the operation feasible? determine (a) drawing force and (b) holding force, given that the tensile strength of the sheet metal (low-carbon steel) = 300 MPa and yield strength = 175 MPa. The die corner radius = 6 mm.

Dies and Presses in sheet metal forming

DIES: The different types of dies used in sheet metal operations are as follows:

1. Simple Die
2. Compound Die
3. Progressive Die

1. **Simple Die:** If only **one** operation is performed in **One Stroke** and at **One Stage** is called as Simple Die.

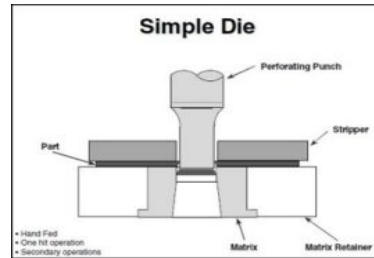

2. **Compound Die:** If more than one cutting operation is performed in one stroke and at one stage called as Compound Die.

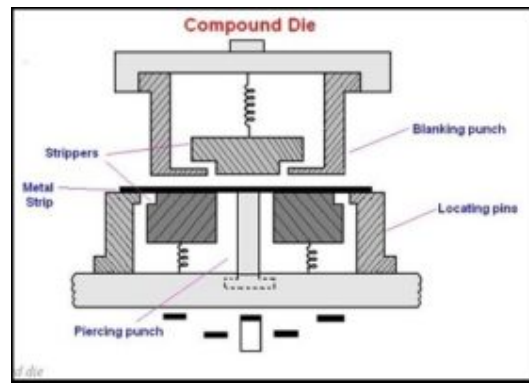

3. **Progressive Die:** In this, more than **one cutting operation** will be performed in **one stroke** but at **different stages** and punched out sheet is progressing from one stage to another stage for completing the punching operations so that **Blanking will be the last operation**.

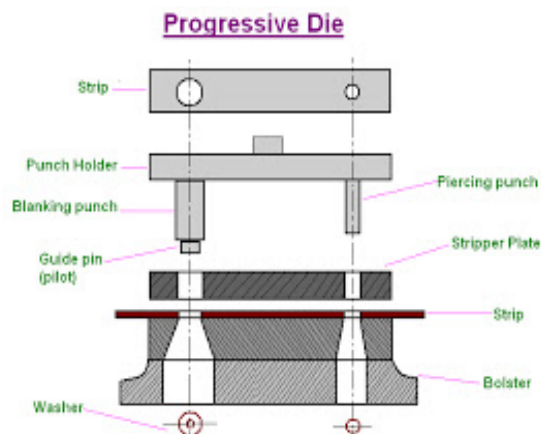

PRESSES: A press used for sheet metalworking is a machine tool with a stationary bed and a powered ram (or slide) that can be driven toward and away from the bed to perform various cutting and forming operations. A typical press, with principal components labeled, is diagram. The relative positions of the bed and ram are established by the frame, and the ram is driven by mechanical or hydraulic power. When a die is mounted in the press, the punch holder is attached to the ram, and the die holder is attached to a bolster plate of the press bed. Press tools are commonly used are: Hydraulic, Pneumatic and mechanical presses

- Mechanical presses: These presses utilize flywheel energy which is transferred to the work piece by gears, cranks, eccentrics, or levers.

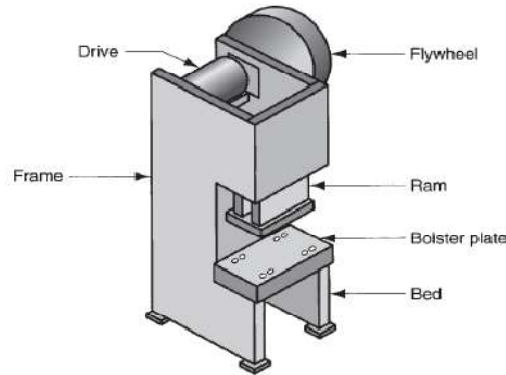

- Hydraulic Presses: These presses provide working force through the application of fluid pressure on a piston by means of pumps, valves, intensifiers, and accumulators. These presses have better performance and reliability than mechanical presses.

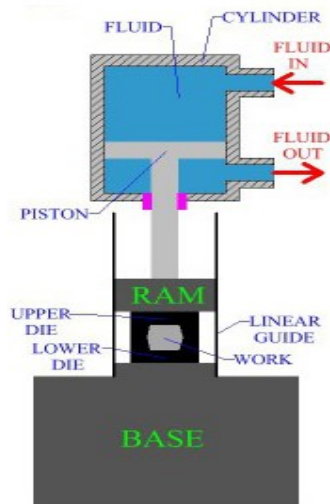

- Pneumatic Presses: These presses utilize air cylinders to exert the required force. These are generally smaller in size and capacity than hydraulic or mechanical presses, and therefore find use for light duty operations only.

FORGING DEFECTS:

1.) Unfilled Section: As the name implies in this type of defect some of the forging section remain unfilled. This is due to poor design of die or poor forging technic. This is also due to less raw material or poor heating. This defect can be removed by proper die design, proper availability of raw material and proper heating.

2.) Cold Shut: Cold shut includes small cracks at corners. These defects occur due to improper design of forging die. It is also due to sharp corner, and excessive chilling in forge product. The fillet radius of the die should be increase to remove these defects.

3.) Scale Pits: Scale pits are due to improper cleaning of forged surface. This defect generally associated with forging in open environment. It is irregular depositions on the surface of forging. It can be removed by proper cleaning of forged surface.

4.) Die Shift: Die shift is caused by misalignment of upper die and lower die. When both these dies are not properly aligned the forged product does not get proper dimensions.

This defect can be removed by proper alignment. It can be done by provide half notch on upper die and half on lower die so at the time of alignment, both these notches will match.

5.) Flakes: These are internal cracks occur due to improper cooling of forge product. When the forge product cooled quickly, these cracks generally occur which can reduce the strength of forge product. This defect can be removed by proper cooling.

6.) Improper Grain Growth: This defect occurs due to improper flow of metal in casting which changes predefined grain structure of product. It can be removed by proper die design

7.) Incomplete Forging Penetration: This defect arises due to incomplete forging. It is due to light or rapid hammer blow. This defect can be removed by proper control on forging press.

8.) Surface Cracking: Surface cracking occurs due to excessive working on surfaces at low temperature. In this defect, so many cracks arise on work piece. This defect can be removed by proper control on working temperature.

9.) Residual Stresses in Forging: This defect occurs due to improper cooling of forged part. Too much rapid cooling is main causes of this type of defects. This can be removed by slow cooling of forged part.